

FD 40-10

CONTI® Double Convolution Air Spring

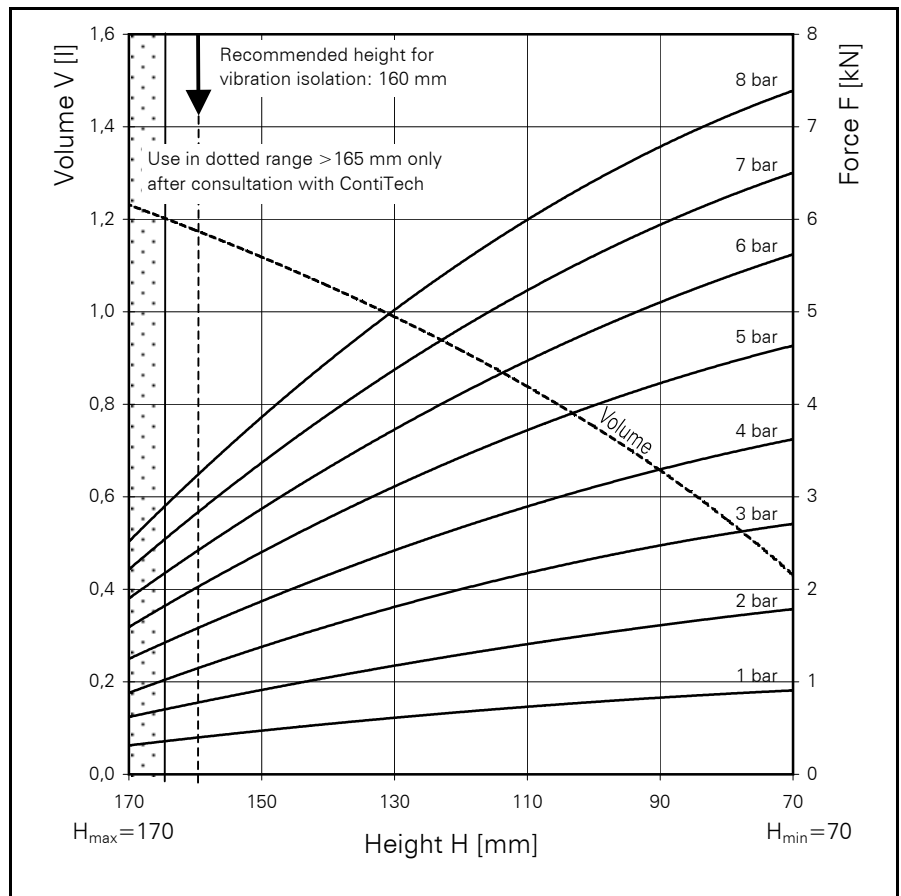
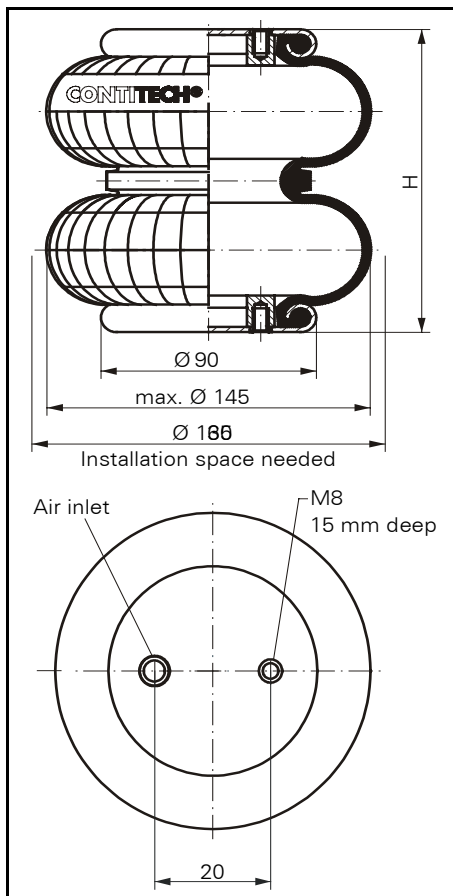

FD 40-10

Force-height diagram

Purchase order data

Type	Order No.
Rubber bellows only	60457
With clamped plates	2682 001 000
G 1/8 air inlet	

Additional types on request

Technical data

Min. pressure	0 bar
Return force to min. height	≤ 200 N
Overall weight with clamped plates	1.1 kg

Vibration isolation - dynamic characteristic values

Design height H: recommended 160mm, minimum 150mm

Pressure p [bar]	3	4	5	6	7	8	Vol.[l]
Force (Load) [kN]	1.1	1.5	2.0	2.4	2.8	3.2	1.2
Spring rate [N/cm]	340	450	580	700	825	950	
Natural frequency [Hz]	2.8	2,8	2.7	2.7	2.7	2.7	

Pneumatic application - static characteristic values

Force F [kN]

Pressure p [bar]	3	4	5	6	7	8	Vol.[l]	
Height H [mm]	160	1.1	1.6	2.0	2.4	2.8	3.2	1.2
	140	1.6	2.2	2.8	3.3	3.9	4.5	1.1
	120	2.0	2.7	3.4	4.1	4.8	5.5	0.9
	100	2.3	3.1	4.0	4.8	5.6	6.4	0.7
	80	2.6	3.5	4.5	5.4	6.3	7.1	0.6



Service instructions
M8 = 25 Nm
G 1/8 = 25 Nm