

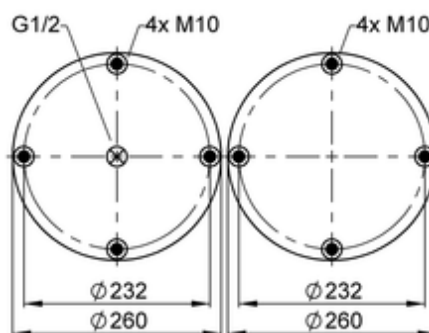

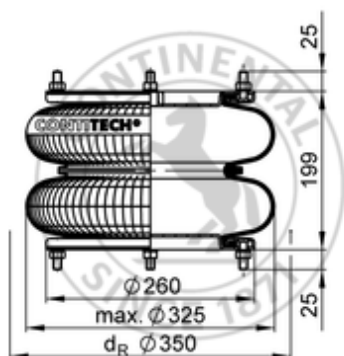







FD 412-18 1/2 M10

66334



-  bolt or stud
-  hole
-  combination stud
-  air inlet
-  stud and nut

 kg	6,9 kg
	incl.
	G1/2: max. 25 Nm
	M10: max. 35 Nm

OE Manufacturer/Reference No.

Manufacturer	Original-part no.	Model
Granning	15813	
Gigant	881202	
Weweler	USN 510011KD	
Gigant	700881202	