

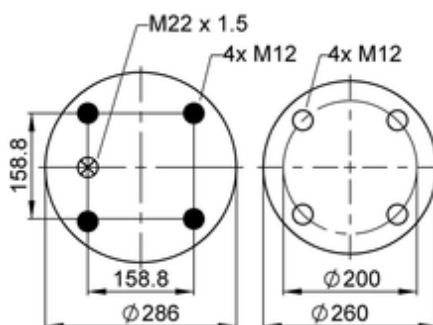

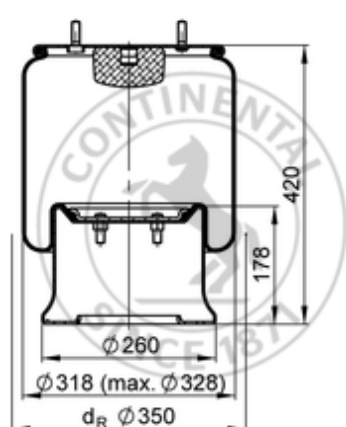



813 MB

67193



 bolt or stud   
  hole   
  combination stud   
  air inlet   
  stud and nut

 kg	13,2 kg
	K002
	
	M12: max. 70 Nm
	M22x1.5: max. 20 Nm

### OE Manufacturer/Reference No.

Manufacturer	Original-part no.	Model
Pegaso	175005	Troner
Paul NFZ	P2700MB0813	
Renault	5.010.130.925	
Renault	5.000.790.692	
Kässbohrer	4.731.030.000	
Kässbohrer	4.731.033.000	
Granning	15634	

Hendrickson	785 170	
Hendrickson	505 859 / 01	Tecair
Hendrickson	505 859	Airpoise <'86
Viberti	128 147 122	
Titan	916 8770 0000	
Traylor	003 6158 E	
Traylor	6502 3482	
Trouillet	ST 225-675	
Viberti	644 285	
SAE	8403 / 102	
SAF - Holland	2.229.2103.00	2923 AR 211-213. AR 413
SAF - Holland	2.229.2403.00	2923 AR 211-213. AR 413
SAF - Holland	2.229.2603.00	2923 AR 211-213. AR 413
SAF - Holland	2.229.0010.00	
SAF - Holland	2.229.0003.00	2923 AR 211-213. AR 413
SAF - Holland	2.229.0003.00	2923 R 112-113. R 142-143
Weweler	US 07345	
Weweler	US 87408	
SAF - Holland	2923	
Scania	1723269	
Meritor	2121 5633	