

Description		Assembly Order No.
Style 113	Blind nuts, 1/4 NPT	W01-358-7103
	Blind nuts, 1/4 NPT, bumper	W01-358-7104
Two Ply Bellows	Blind nuts, 3/4 NPT	W01-358-7101
	Blind nuts, 3/4 NPT, bumper	W01-358-7109
	Countersunk steel bead rings, 1 3/4 bolts, nuts, washers	W01-358-7110
	Blind nuts, 1/8 NPT	W01-753-7113
	Blind nuts, 1 1/4 NPT	W01-753-7114
	Rubber bellows only	W01-358-0135

Assembly weight..... 14.1 lbs.
Force to collapse to minimum height (@ 0 PSIG)..... 17 lbs.

Style 128	Blind nuts, 1/4 NPT	W01-358-8151
	Blind nuts, 1/4 NPT, rubber bumper	W01-358-8149
High Strength Bellows	Blind nuts, 3/4 NPT	W01-358-8152
	Blind nuts, 3/4 NPT, rubber bumper	W01-358-8150
	Rubber bellows only	W01-358-0231

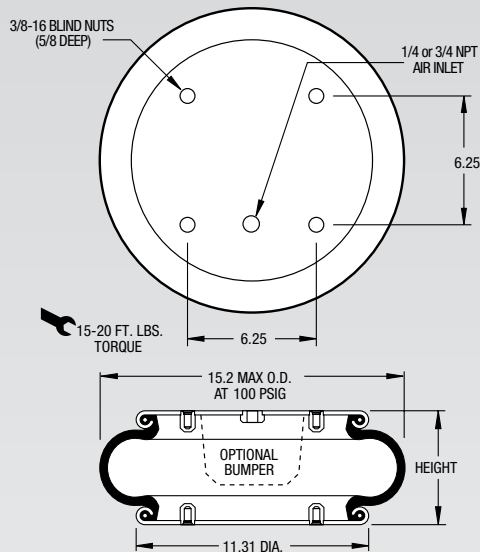

NOTE: A bead plate part is shown. This part is also available with bead rings. See pages 8-10 for explanation.

Dynamic Characteristics at 5.0 in. Design Height (Required for Airmount isolator design only)				
Volume @ 100 PSIG = 601 in ³			Natural Frequency	
Gage Pressure (PSIG)	Load (lbs.)	Spring Rate (lbs./in.)	CPM	HZ
40	3,010	2,322	165	2.75
60	4,610	3,288	158	2.64
80	6,460	4,247	152	2.54
100	8,320	5,176	148	2.47

Recommended Design Position Static Pressure 0-100 psi
RECOMMENDED AIRMOUNT DESIGN HEIGHT 5.0 INCHES

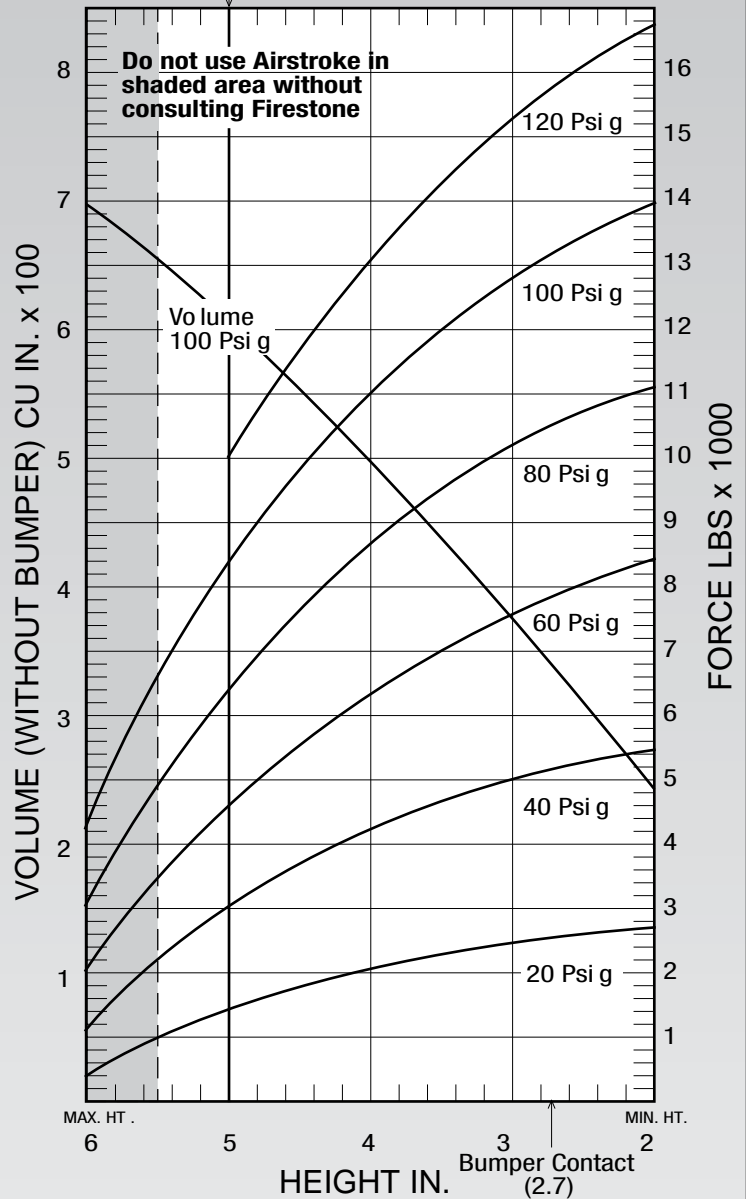

See page 12 for instructions on how to use chart.

Force Table (Use for Airstroke™ actuator design)						
Assembly Height (in.)	Volume @ 100 PSIG (in ³)	Pounds Force				
		@20 PSIG	@40 PSIG	@60 PSIG	@80 PSIG	@100 PSIG
5.0	601	1,420	3,010	4,610	6,460	8,320
4.0	499	2,030	4,160	6,340	8,640	10,820
3.0	375	2,430	5,000	7,610	10,220	12,820