

Description		Assembly Order No.
Style 131	Blind nuts, 1/4 NPT	W01-358-7731
	Blind nuts, 3/4 NPT	W01-358-7742
Two Ply Bellows	Socket head aluminum bead rings (bolts, nuts, washers not included-use 1/4 cap screws)	W01-358-0127
	3/4 NPT (only) upper plate, blind nuts lower plate	W01-358-7729
	Rubber bellows only	W01-358-0131
Assembly weight.....		2.8 lbs.
Force to collapse to minimum height (@ 0 PSIG).....		32 lbs.

Recommended Design Position Static Pressure 0-100 psi

RECOMMENDED AIRMOUNT DESIGN HEIGHT 3.5 INCHES

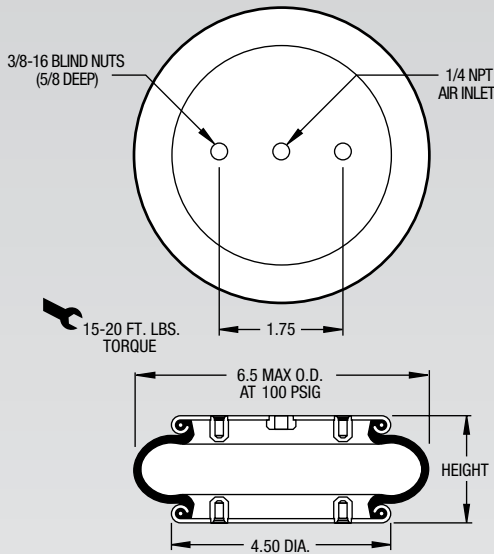

NOTE: A bead plate part is shown. This part is also available with bead rings. Bolts are not included. See pages 8-10 for explanation.

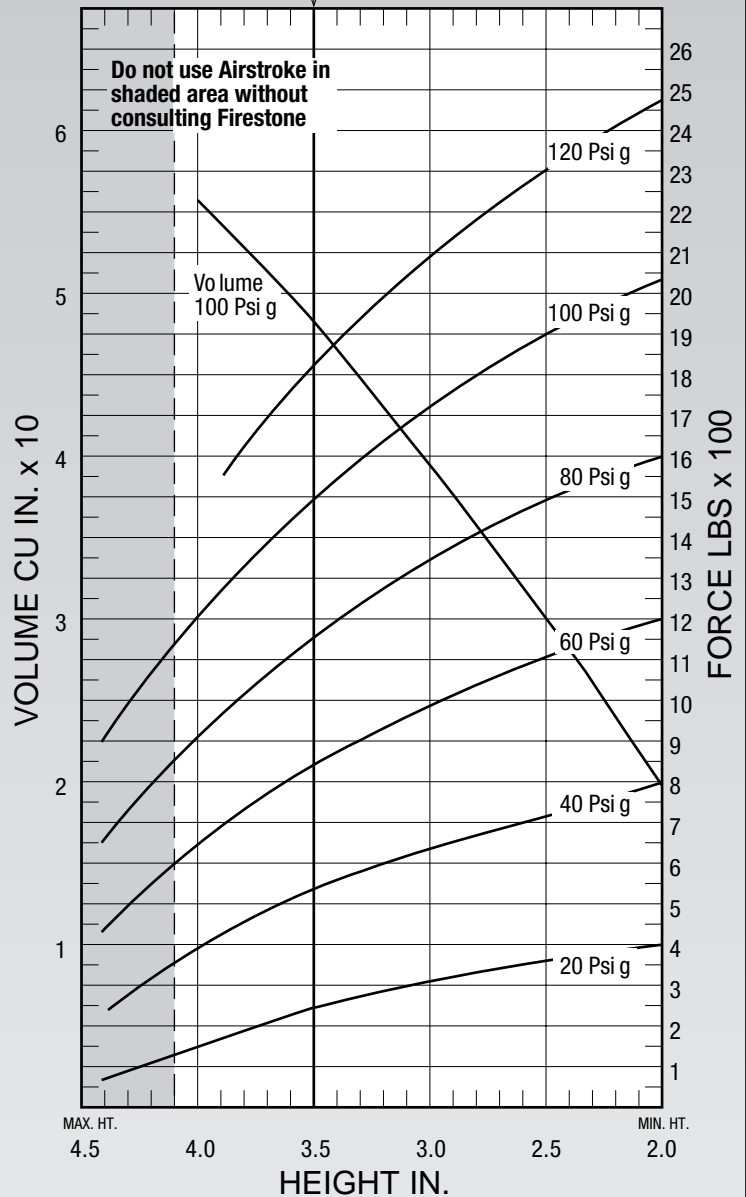

See page 12 for instructions on how to use chart.

Dynamic Characteristics at 3.5 in. Design Height (Required for Airmount isolator design only)				
Volume @ 100 PSIG = 53 in ³			Natural Frequency	
Gage Pressure (PSIG)	Load (lbs.)	Spring Rate (lbs./in.)	CPM	HZ
40	550	587	195	3.25
60	850	833	186	3.09
80	1,170	1,082	181	3.01
100	1,510	1,331	176	2.94

Force Table (Use for Airstroke™ actuator design)						
Assembly Height (in.)	Volume @ 100 PSIG (in ³)	Pounds Force				
		@20 PSIG	@40 PSIG	@60 PSIG	@80 PSIG	@100 PSIG
4.0	56	160	400	650	910	1,210
3.0	39	310	640	990	1,350	1,730
2.0	20	390	790	1,200	1,600	2,050