

NOTE: All Assembly Order Numbers are for bead ring parts unless noted otherwise.

	Description	Assembly Order No.
Style 138-1.5	Ribbed neck aluminum bead rings (equal spacing), 45 mm bolts, nuts, washers	W01-M58-6972
High Strength Construction	Rubber bellows only	W01-358-0147
Assembly weight.....		11.11 kg.
Force to collapse to minimum height (@ 0 BAR)		667 N.

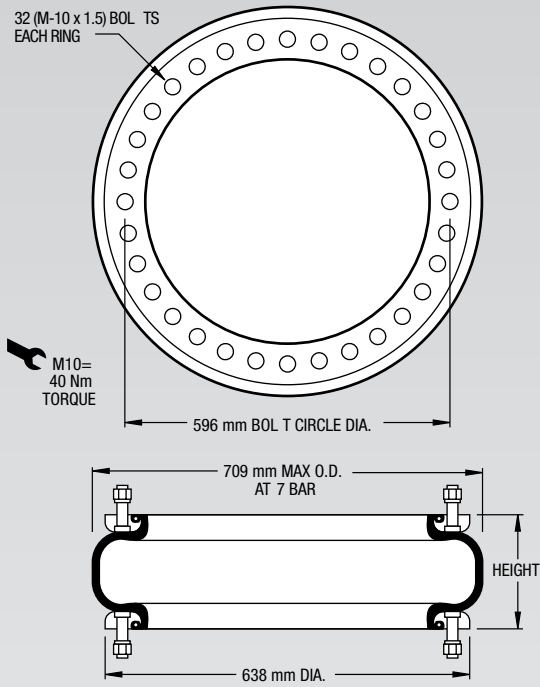

NOTE: A bead ring part is shown. This part is also available with rolled plates. See page 11 for explanation.

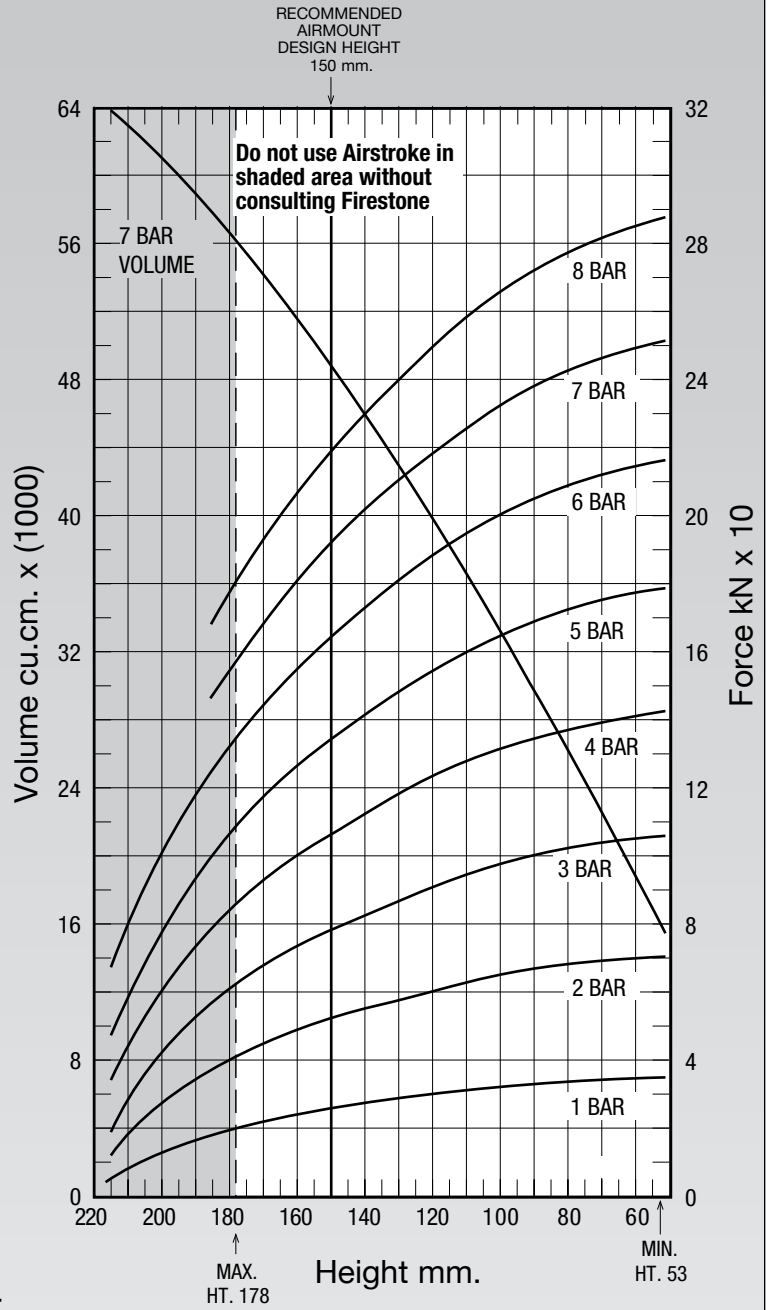

See page 12 for instructions on how to use chart.

Dynamic Characteristics at 150 mm Design Height (Required for Airmount isolator design only)			
Gauge Pressure (BAR)	Load (kN)	Spring Rate (kN/m)	Natural Frequency Hz
3	78.40	1361	2.08
4	106.51	1742	2.02
5	134.29	2111	1.98
6	164.07	2488	1.94
7	191.19	2844	1.92

Force Table (Use for Airstroke™ actuator design)							
Assembly Height (mm)	Volume @ 7 BAR (cu cm)	EFF Area @ 7 BAR (cm sq)	kN Force				
			@ 3 BAR	@ 4 BAR	@ 5 BAR	@ 6 BAR	@ 7 BAR
180	56558	2200	60.35	83.40	106.09	131.40	153.99
160	51417	2573	73.03	99.66	125.96	154.37	180.09
140	45680	2871	83.06	112.54	141.62	172.60	200.97
120	39615	3120	91.25	123.17	154.62	187.80	218.40
100	33114	3322	97.72	131.55	165.06	200.15	232.53
80	26237	3471	102.53	137.62	172.72	209.27	242.92
60	19043	3567	105.89	141.79	177.80	215.18	249.69