

Description		Assembly Order No.
Style 19	Blind nuts, 1/4 NPT	W01-358-7008
	Blind nuts, 1/4 NPT, bumper	W01-358-7009
Two Ply Bellows	Blind nuts, 3/4 NPT	W01-358-7011
	Blind nuts, 3/4 NPT, bumper	W01-358-7012
	Countersunk steel bead rings, 1 ⁵ / ₈ bolts, nuts, washers	W01-358-7023
	Rubber bellows only	W01-358-0134
Assembly weight.....		9.6 lbs.
Force to collapse to minimum height (@ 0 PSIG)		9 lbs.

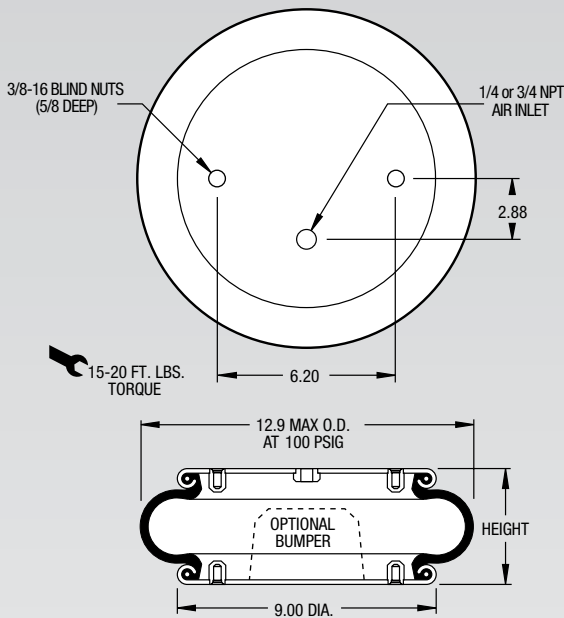

NOTE: A bead plate part is shown. This part is also available with bead rings. See pages 8-10 for explanation.

Recommended Design Position Static Pressure 0-100 psi
RECOMMENDED AIRMOUNT DESIGN HEIGHT 5.0 INCHES

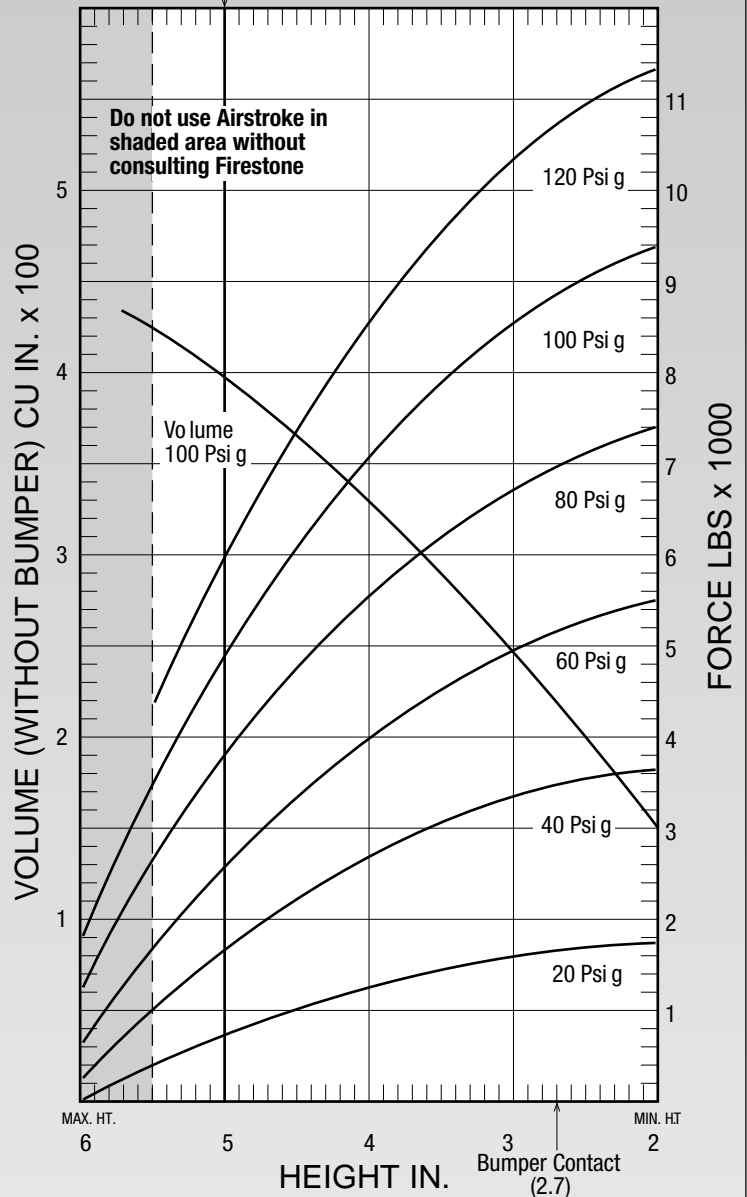

See page 12 for instructions on how to use chart.

Dynamic Characteristics at 5.0 in. Design Height (Required for Airmount isolator design only)				
Volume @ 100 PSIG = 394 in ³			Natural Frequency	
Gage Pressure (PSIG)	Load (lbs.)	Spring Rate (lbs./in.)	CPM	HZ
40	1,690	1,607	183	3.06
60	2,640	2,322	176	2.93
80	3,730	3,000	168	2.81
100	4,870	3,669	163	2.72

Force Table (Use for Airstroke™ actuator design)						
Assembly Height (in.)	Volume @ 100 PSIG (in ³)	Pounds Force				
		@20 PSIG	@40 PSIG	@60 PSIG	@80 PSIG	@100 PSIG
5.0	394	780	1,690	2,640	3,730	4,870
4.0	327	1,300	2,610	4,060	5,500	7,050
3.0	244	1,580	3,280	5,000	6,720	8,440