

	Description	Assembly Order No.
Style 20-2	Blind nuts, 1/4 NPT	W01-358-6951
	Blind nuts, 1/4 NPT, rubber bumper	W01-358-6947
Two Ply Bellows	Blind nuts, 3/4 NPT	W01-358-6952
	Countersunk steel bead rings, 1 3/4 bolts, nuts, washers	W01-358-7789
	Rubber bellows only	W01-358-0305
Assembly weight.....		7.7 lbs.
Force to collapse to minimum height (@ 0 PSIG)		17 lbs.

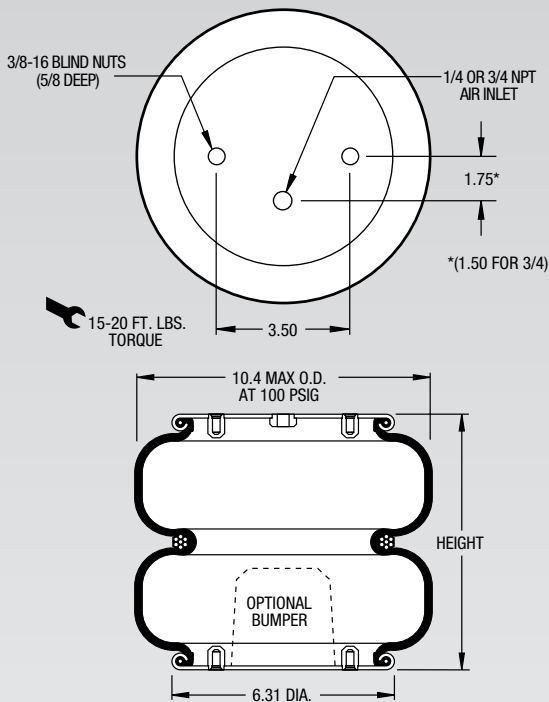

NOTE: The bellows extends beyond the bead plates at minimum height

NOTE: A bead plate part is shown. This part is also available with bead rings. See pages 8-10 for explanation.

Dynamic Characteristics at 10.0 in. Design Height Consult factory before using as an Airmount isolator.				
Volume @ 100 PSIG = 488 in ³			Natural Frequency	
Gage Pressure (PSIG)	Load (lbs.)	Spring Rate (lbs./in.)	CPM	HZ
40	1,184	376	106	1.77
60	1,848	534	101	1.68
80	2,531	669	97	1.61
100	3,238	813	94	1.57

CONSULT FIRESTONE BEFORE USING AS AIRMOUNT
RECOMMENDED AIRMOUNT DESIGN HEIGHT 10.0 INCHES

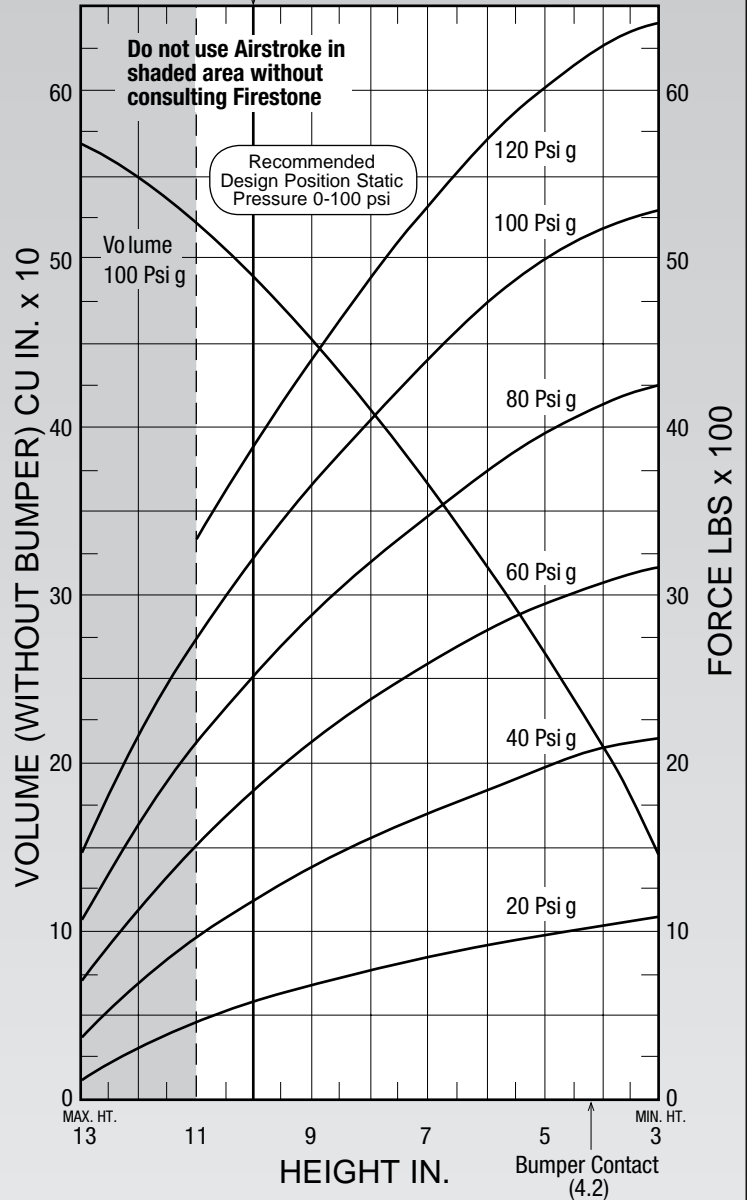

See page 12 for instructions on how to use chart.

Force Table (Use for Airstroke™ actuator design)						
Assembly Height (in.)	Volume @ 100 PSIG (in ³)	Pounds Force				
		@20 PSIG	@40 PSIG	@60 PSIG	@80 PSIG	@100 PSIG
11.0	520	449	951	1,517	2,122	2,753
10.0	488	572	1,184	1,848	2,531	3,238
9.0	451	673	1,384	2,134	2,880	3,661
8.0	409	759	1,554	2,377	3,193	4,049
7.0	364	836	1,704	2,590	3,485	4,416
6.0	316	907	1,845	2,786	3,753	4,748
5.0	256	975	1,979	2,954	3,968	5,005