

NOTE: All Assembly Order Numbers are for bead ring parts unless noted otherwise.

	Description	Assembly Order No.
Style 203	Ribbed neck aluminum bead rings (equal spacing), 45 mm bolts, nuts, washers	W01-M58-6985
Two Ply Bellows	Rolled plate assembly, 1/2 blind nuts, 3/4 NPT	W01-358-7767
	Rubber bellows only	W01-358-0205
Assembly weight.....		10.80 kg.
Force to collapse to minimum height (@ 0 BAR)		178 N.

	Description	Assembly Order No.
Style 218	Ribbed neck aluminum bead rings (equal spacing), 45 mm bolts, nuts, washers	W01-M58-6986
High Strength Construction	Rubber bellows only	W01-358-0219

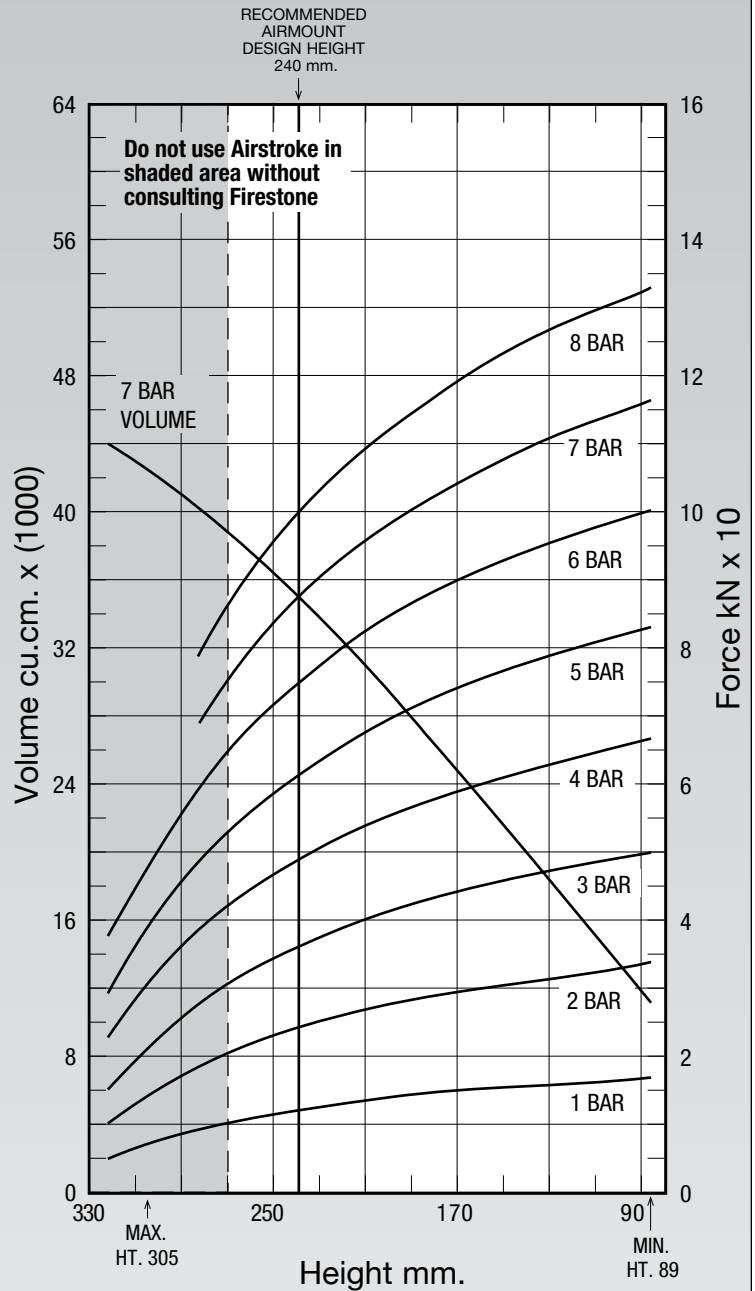
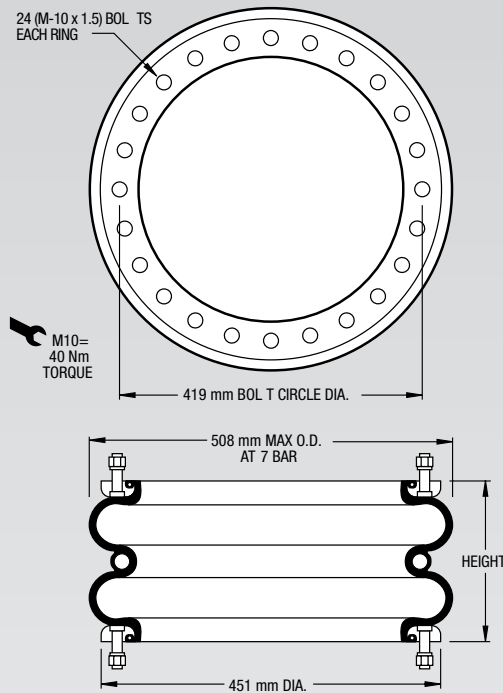

See page 12 for instructions on how to use chart.

NOTE: A bead ring part is shown. This part is also available with rolled plates. See page 11 for explanation.

*Increase the minimum height by 18 mm. Add 18 mm to the height (bottom axis) before reading loads.

Gauge Pressure (BAR)	Load (kN)	Spring Rate (kN/m)	Natural Frequency Hz
3	35.98	409	1.68
4	48.73	516	1.62
5	61.33	627	1.60
6	74.72	745	1.57
7	86.97	856	1.56

Assembly Height (mm)	Volume @ 7 BAR (cu cm)	EFF Area @ 7 BAR (cm sq)	kN Force				
			@ 3 BAR	@ 4 BAR	@ 5 BAR	@ 6 BAR	@ 7 BAR
260	37836	1132	32.38	44.21	55.77	68.08	79.26
240	35328	1243	35.98	48.73	61.33	74.72	86.97
220	32638	1331	38.91	52.40	65.84	80.08	93.18
200	29694	1404	41.34	55.43	69.58	84.51	98.30
180	26610	1467	43.38	57.99	72.78	88.32	102.65
160	23416	1520	45.15	60.21	75.56	91.62	106.42
140	20139	1567	46.72	62.20	77.99	94.46	109.68
120	16912	1607	48.13	64.04	80.11	96.86	112.48