

Description		Assembly Order No.
Style 224	Blind nuts, 1/4 NPT	W01-358-3400
	Blind nuts, 3/4 NPT	W01-358-3403
Two Ply Bellows	Countersunk steel bead rings, 1 3/4 bolts, nuts, washers,	W01-358-3407
Assembly weight.....		5.0 lbs.
Force to collapse to minimum height (@ 0 PSIG)		14 lbs.

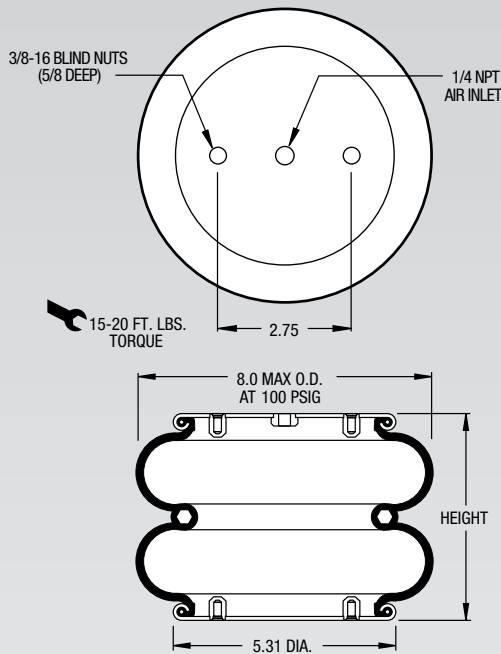

NOTE: A bead plate part is shown. This part is also available with bead rings. See pages 8-10 for explanation.

Dynamic Characteristics at 6.5 in. Design Height (Required for Airmount isolator design only)				
Volume @ 100 PSIG = 171 in ³			Natural Frequency	
Gage Pressure (PSIG)	Load (lbs.)	Spring Rate (lbs./in.)	CPM	HZ
40	730	361	132	2.20
60	1,130	523	128	2.13
80	1,530	690	126	2.10
100	1,940	849	124	2.07

Recommended Design Position Static Pressure 0-100 psi

RECOMMENDED AIRMOUNT DESIGN HEIGHT 6.5 INCHES

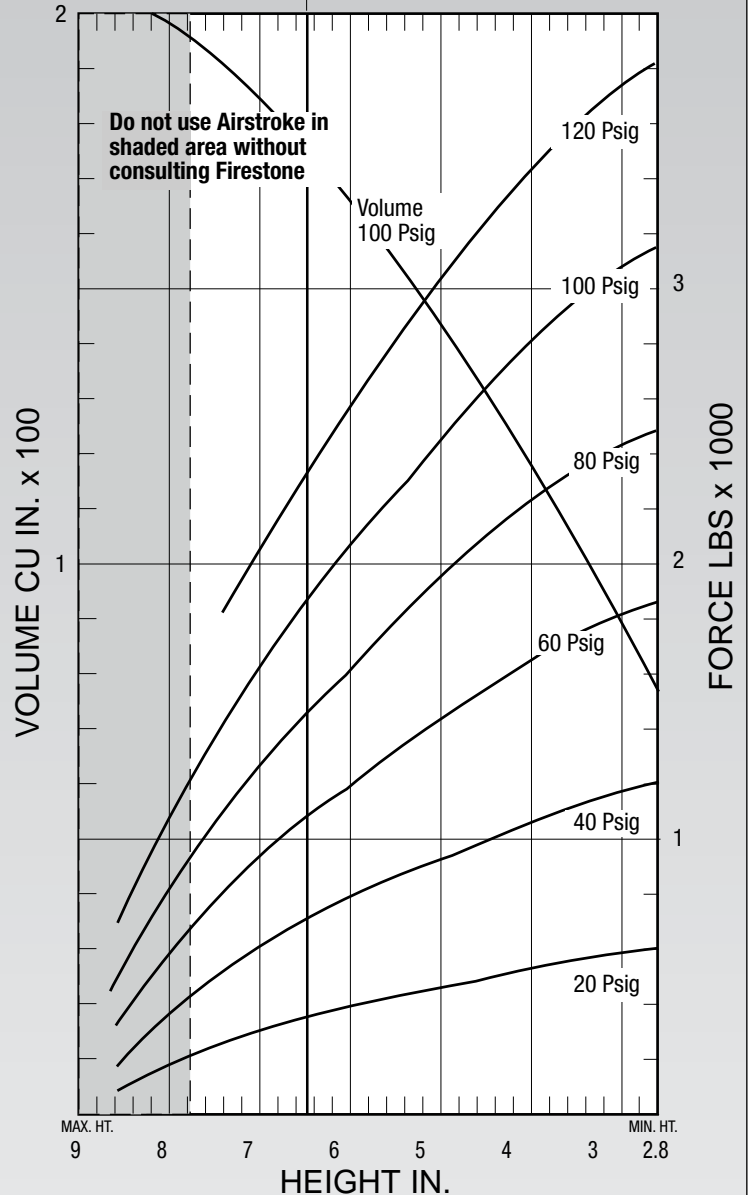

See page 12 for instructions on how to use chart.

Force Table (Use for Airstroke™ actuator design)						
Assembly Height (in.)	Volume @ 100 PSIG (in ³)	Pounds Force				
		@20 PSIG	@40 PSIG	@60 PSIG	@80 PSIG	@100 PSIG
7.0	181	320	630	990	1,340	1,710
6.0	160	400	820	1,260	1,700	2,160
5.0	134	470	960	1,490	2,040	2,570
4.0	105	550	1,110	1,720	2,310	2,930
3.0	73	590	1,210	1,860	2,480	3,150