

**NOTE: All Assembly Order Numbers are for bead plate parts unless noted otherwise.**

	Description	Assembly Order No.
Style 233-2	Blind nuts, 1/4 BSP	W01-M58-6107
	Blind nuts, 3/4 BSP	W01-M58-6109
Two Ply Bellows		
Assembly weight.....		8.89 kg.
Force to collapse to minimum height (@ 0 BAR)		455 N.

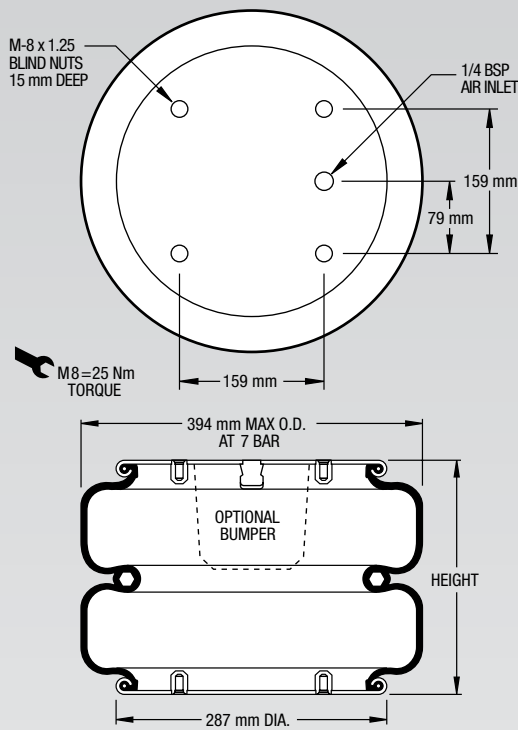

**NOTE: The bellows extends beyond the bead plates at minimum height.**

**NOTE: A bead plate part is shown. This part is also available with bead rings. See pages 8-10 for explanation.**

Dynamic Characteristics at 285 mm Design Height (Required for Airmount isolator design only)			
Gauge Pressure (BAR)	Load (kN)	Spring Rate (kN/m)	Natural Frequency Hz
3	17.48	164	1.53
4	24.14	208	1.46
5	30.73	251	1.43
6	38.28	299	1.39
7	45.04	345	1.38

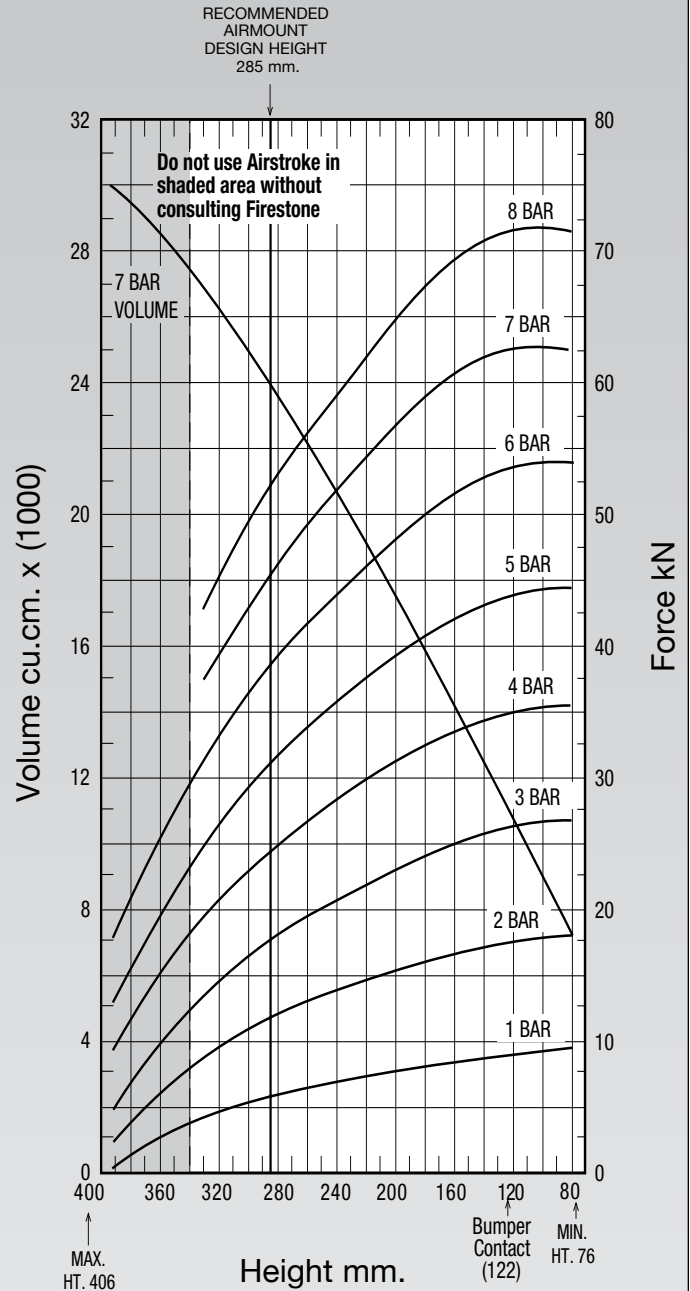

See page 12 for instructions on how to use chart.

Force Table (Use for Airstroke™ actuator design)							
Assembly Height (mm)	Volume @ 7 BAR (cu cm)	EFF Area @ 7 BAR (cm sq)	kN Force				
			@ 3 BAR	@ 4 BAR	@ 5 BAR	@ 6 BAR	@ 7 BAR
320	26309	560	14.44	20.52	26.35	33.20	39.23
280	23714	653	17.82	24.56	31.24	38.87	45.73
240	20846	729	20.39	27.85	35.13	43.41	51.04
200	17673	799	22.69	30.81	38.73	47.65	55.94
160	14250	859	24.68	33.30	41.87	51.34	60.11
120	10748	892	25.94	34.86	43.76	53.44	62.41
80	6382	889	26.62	35.40	44.31	53.60	62.25