

NOTE: All Assembly Order Numbers are for bead ring parts unless noted otherwise.

	Description	Assembly Order No.
Style 248-2	Ribbed neck aluminum bead rings (equal spacing), 45 mm bolts, nuts, washers	W01-M58-6970
High Strength Construction	Rubber bellows only	W01-358-1022
Assembly weight.....		32.88 kg.
Force to collapse to minimum height (@ 0 BAR)		1556 N.

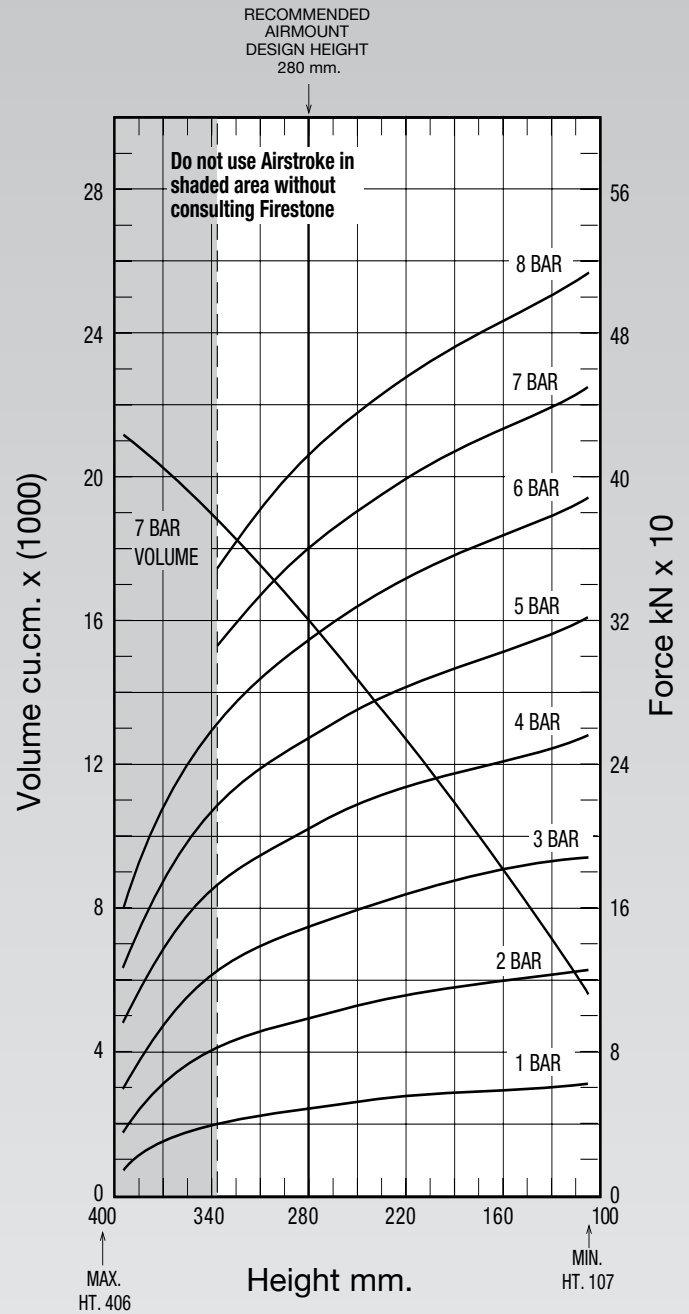
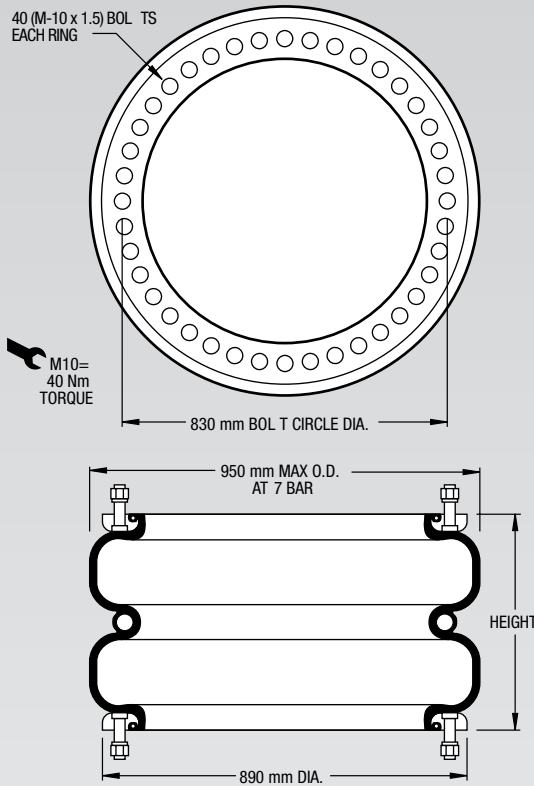

See page 12 for instructions on how to use chart.

NOTE: The effective length of the 45 mm bolt is 30 mm in this bead ring.

Dynamic Characteristics at 280 mm Design Height (Required for Airmount isolator design only)			
Gauge Pressure (BAR)	Load (kN)	Spring Rate (kN/m)	Natural Frequency Hz
3	150.00	1245	1.44
4	204.75	1600	1.39
5	255.83	1923	1.37
6	309.73	2281	1.35
7	360.26	2628	1.35

Force Table (Use for Airstroke™ actuator design)							
Assembly Height (mm)	Volume @ 7 BAR (cu cm)	EFF Area @ 7 BAR (cm sq)	kN Force				
			@ 3 BAR	@ 4 BAR	@ 5 BAR	@ 6 BAR	@ 7 BAR
320	180105	4643	133.77	183.62	230.28	279.45	324.96
280	160037	5147	150.00	204.75	255.83	309.73	360.26
240	138633	5549	162.94	220.93	275.60	333.61	388.39
200	115452	5858	174.20	233.51	291.87	352.93	410.04
160	90693	6106	182.57	242.51	304.68	368.72	427.34
120	65396	6367	188.40	252.37	317.21	384.29	445.66