

**NOTE: All Assembly Order Numbers are for bead plate parts unless noted otherwise.**

|                                               | Description                                              | Assembly Order No. |
|-----------------------------------------------|----------------------------------------------------------|--------------------|
| Style 26                                      | Blind nuts, 1/4 BSP                                      | W01-M58-6353       |
|                                               | Blind nuts, 3/4 BSP                                      | W01-M58-6387       |
| Two Ply Bellows                               | Countersunk steel bead rings, 40 mm bolts, nuts, washers | W01-M58-6988       |
|                                               | Rubber bellows only                                      | W01-358-0142       |
| Assembly weight.....                          |                                                          | 2.40 kg.           |
| Force to collapse to minimum height (@ 0 BAR) |                                                          | 102 N.             |

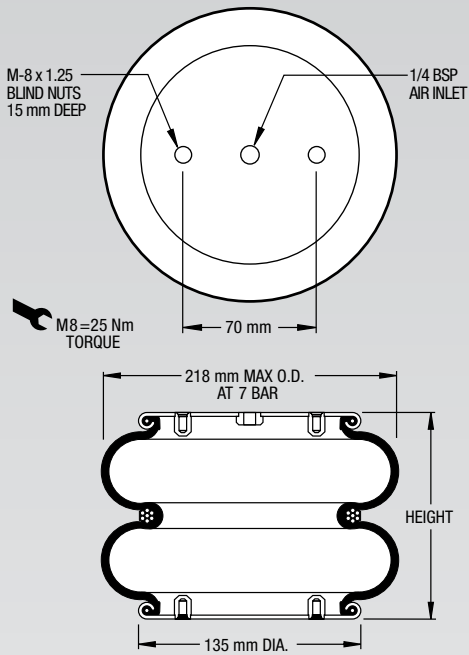

**NOTE: A bead plate part is shown. This part is also available with bead rings. See pages 8-10 for explanation.**

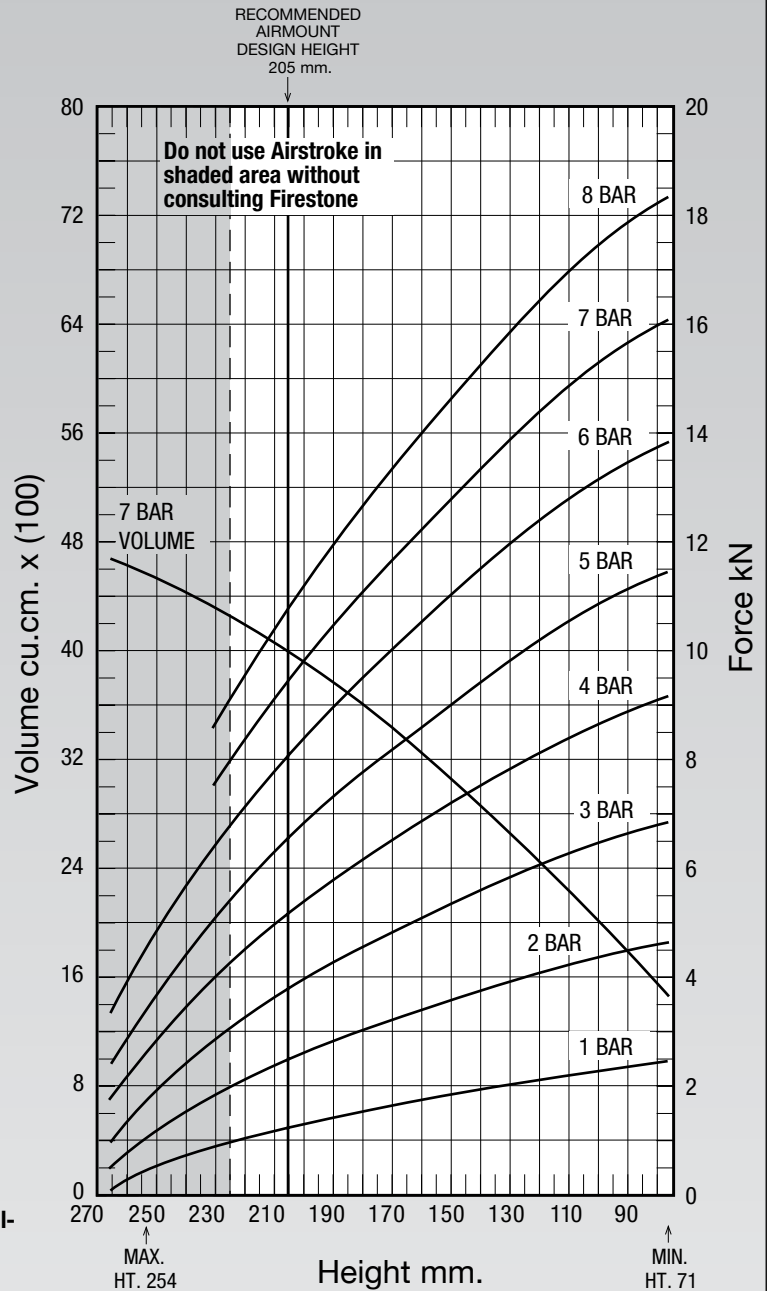

See page 12 for instructions on how to use chart.

| Gauge Pressure (BAR) | Load (kN) | Spring Rate (kN/m) | Natural Frequency Hz |
|----------------------|-----------|--------------------|----------------------|
| 3                    | 3.74      | 59                 | 1.99                 |
| 4                    | 5.15      | 76                 | 1.92                 |
| 5                    | 6.52      | 93                 | 1.88                 |
| 6                    | 8.03      | 109                | 1.83                 |
| 7                    | 9.41      | 124                | 1.81                 |

| Assembly Height (mm) | Volume @ 7 BAR (cu cm) | EFF Area @ 7 BAR (cm sq) | kN Force |         |         |         |         |
|----------------------|------------------------|--------------------------|----------|---------|---------|---------|---------|
|                      |                        |                          | @ 3 BAR  | @ 4 BAR | @ 5 BAR | @ 6 BAR | @ 7 BAR |
| 220                  | 4202                   | 118                      | 3.19     | 4.44    | 5.66    | 7.06    | 8.29    |
| 200                  | 3918                   | 139                      | 3.90     | 5.35    | 6.76    | 8.32    | 9.73    |
| 180                  | 3594                   | 157                      | 4.51     | 6.12    | 7.70    | 9.43    | 11.00   |
| 160                  | 3233                   | 174                      | 5.08     | 6.82    | 8.57    | 10.46   | 12.20   |
| 140                  | 2840                   | 191                      | 5.60     | 7.48    | 9.40    | 11.46   | 13.35   |
| 120                  | 2434                   | 206                      | 6.05     | 8.09    | 10.16   | 12.36   | 14.38   |
| 100                  | 2007                   | 218                      | 6.42     | 8.63    | 10.81   | 13.11   | 15.25   |
| 80                   | 1564                   | 228                      | 6.76     | 9.08    | 11.34   | 13.72   | 15.94   |