

Description		Assembly Order No.
Style 26	Blind nuts, 1/4 NPT	W01-358-7325
	Blind nuts, 3/4 NPT	W01-358-7327
Two Ply Bellows	Countersunk steel bead rings, 1 3/4 bolts, nuts, washers	W01-358-7333
	Rubber bellows only	W01-358-0142
Assembly weight.....		5.3 lbs.
Force to collapse to minimum height (@ 0 PSIG).....		23 lbs.

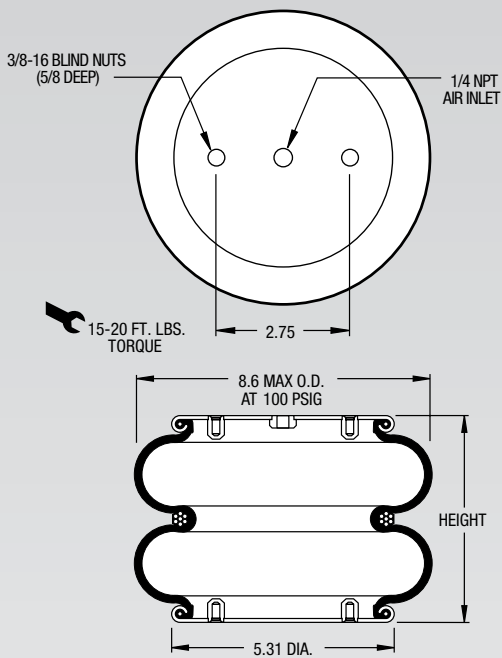

NOTE: A bead plate part is shown. This part is also available with bead rings. See pages 8-10 for explanation.

Dynamic Characteristics at 8.0 in. Design Height (Required for Airmount isolator design only)				
Volume @ 100 PSIG = 246 in ³			Natural Frequency	
Gage Pressure (PSIG)	Load (lbs.)	Spring Rate (lbs./in.)	CPM	HZ
40	590	348	144	2.41
60	980	451	128	2.13
80	1,360	589	123	2.04
100	1,780	732	121	2.01

Recommended Design Position Static Pressure 0-100 psi

RECOMMENDED AIRMOUNT DESIGN HEIGHT 8.0 INCHES

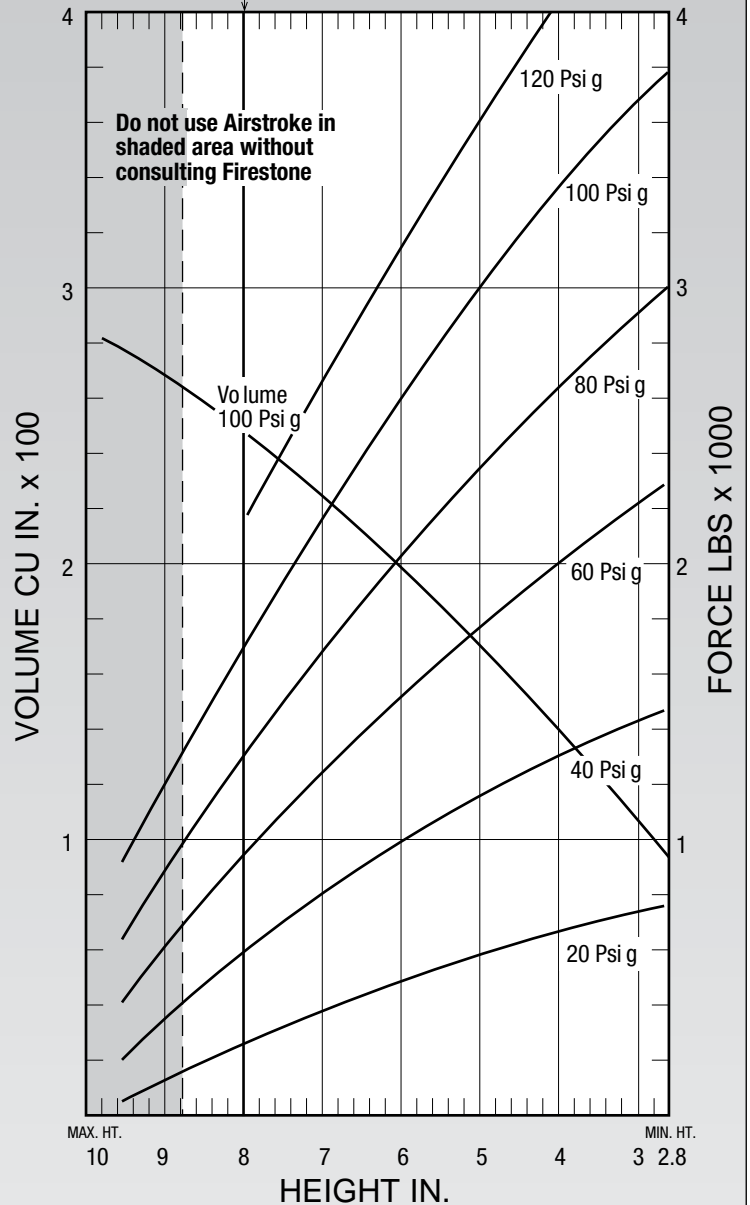

MAX. HT. 10 9 8 7 6 5 4 3 2.8 MIN. HT.

See page 12 for instructions on how to use chart.

Force Table (Use for Airstroke™ actuator design)						
Assembly Height (in.)	Volume @ 100 PSIG (in ³)	Pounds Force				
		@20 PSIG	@40 PSIG	@60 PSIG	@80 PSIG	@100 PSIG
8.0	246	270	590	980	1,360	1,780
7.0	233	390	810	1,270	1,740	2,240
6.0	196	480	1,010	1,530	2,060	2,630
5.0	164	570	1,180	1,780	2,420	3,110
4.0	128	660	1,340	2,010	2,750	3,510