

FS 120-9

CONTI® Single Convolution Air Spring

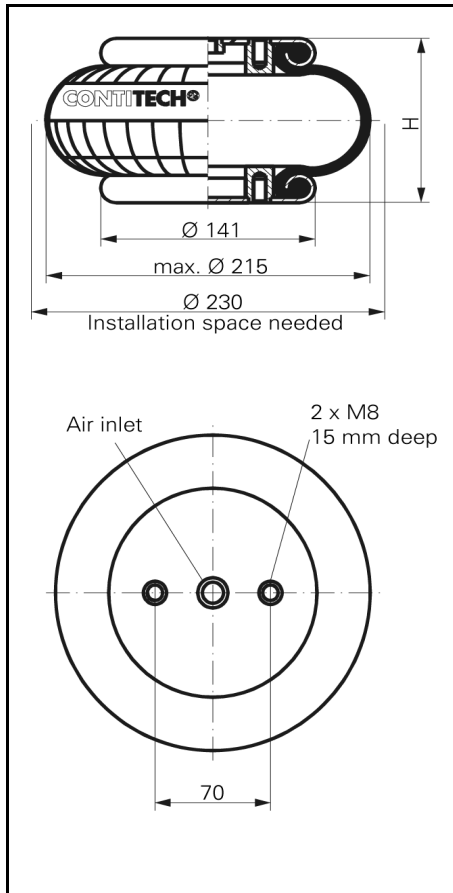

FS 120-9

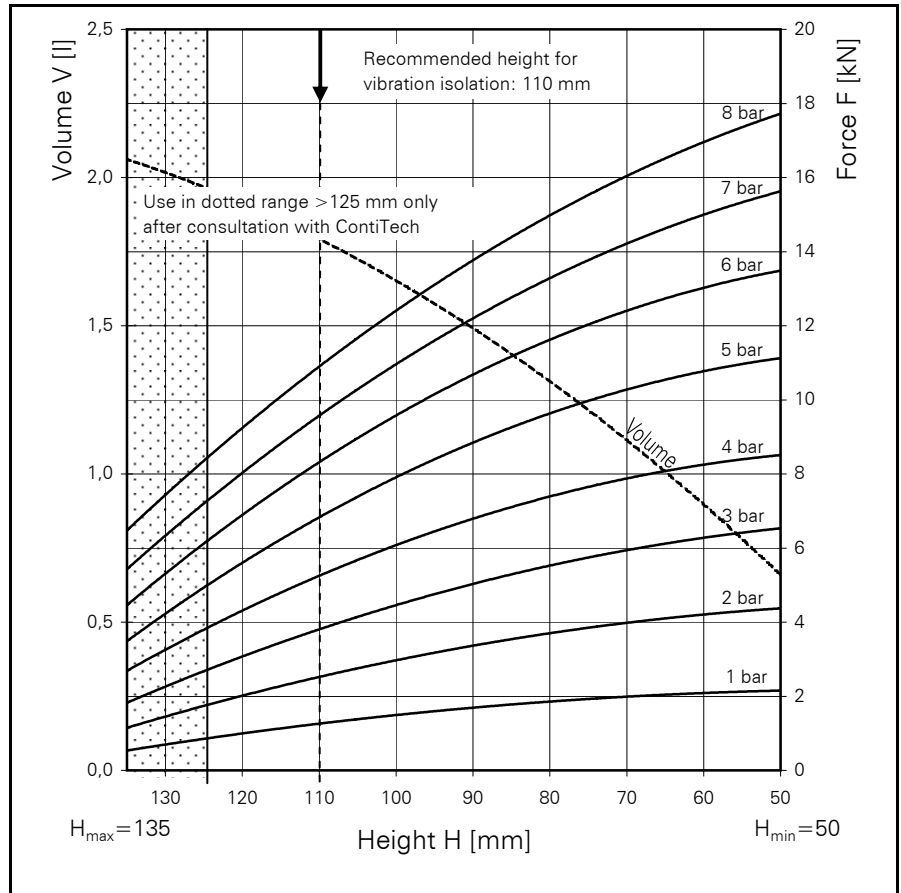

Force-height diagram

Purchase order data

Type	Order No.
Rubber bellows only	60479
With clamped plates G 3/4 air inlet	2681 030 000
With clamped plates G 1/4 air inlet	61358

Additional types on request

Technical data

Min. pressure	0 bar
Return force to min. height	≤ 200 N
Overall weight with clamped plates	2.0 kg

Vibration isolation - dynamic characteristic values

Design height H: recommended 110mm, minimum 90mm

Pressure p [bar]	3	4	5	6	7	8	Vol. V [l]
Force (Load) [kN]	3.9	5.3	6.8	8.3	9.6	10.9	1.8
Spring rate [N/cm]	1315	1620	1925	2230	2535	2840	
Natural frequency [Hz]	2.9	2.8	2.7	2.6	2.6	2.6	

Pneumatic application - static characteristic values

Force F [kN]

Pressure p [bar]	3	4	5	6	7	8	Vol.[l]	
Height H [mm]	120	3.1	4.3	5.6	6.9	8.0	9.2	1.9
	110	3.9	5.3	6.8	8.3	9.6	10.9	1.8
	100	4.5	6.1	7.9	9.7	11.0	12.4	1.7
	90	5.0	6.8	8.9	10.8	12.2	13.8	1.5
	80	5.5	7.4	9.7	11.6	13.3	15.0	1.3
	70	5.9	7.9	10.3	12.3	14.2	16.0	1.1
	60	6.3	8.2	10.7	13.0	15.0	17.0	0.9



Service instructions
M8 = 25 Nm
G 3/4 = 50 Nm