

FS 40-6

CONTI® Single Convolution Air Spring

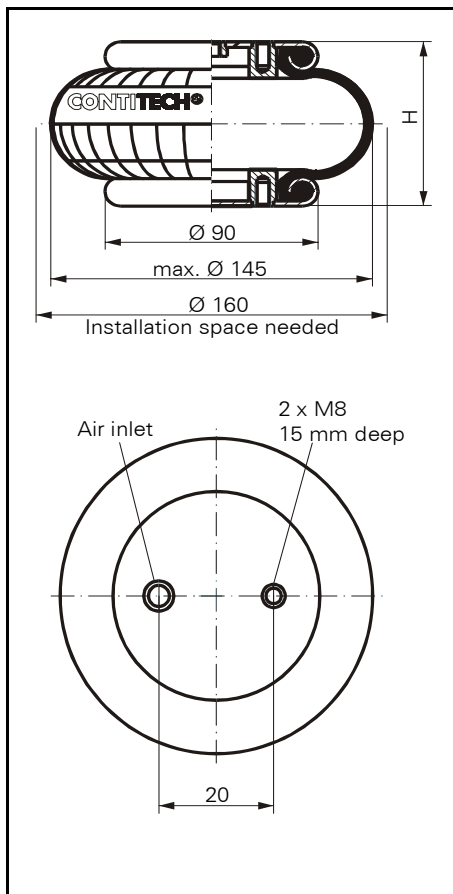

FS 40-6

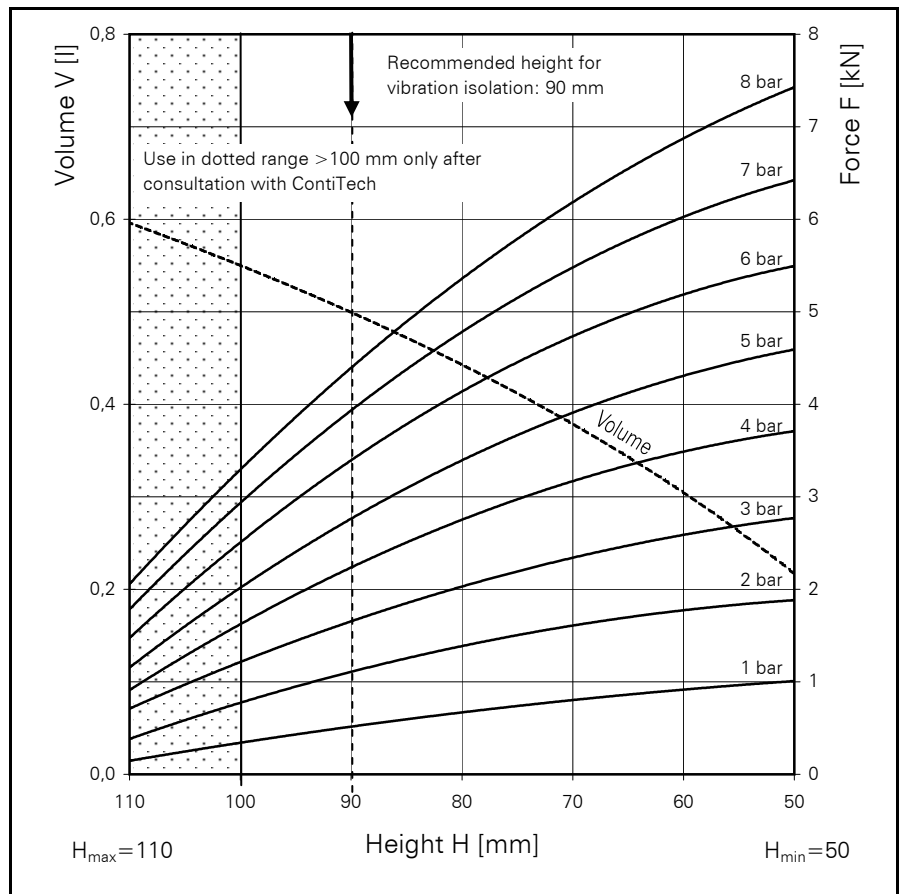

Force-height diagram

Purchase order data

Type	Order No.
Rubber bellows only	60507
With clamped plates	2681 001 000
G 1/4 air inlet	

Additional types on request

Technical data

Min. pressure	0 bar
Return force to min. height	≤ 120 N
Overall weight with clamped plates	0.9 kg

Vibration isolation - dynamic characteristic values

Design height H: recommended 90mm, minimum 70mm

Pressure p [bar]	3	4	5	6	7	8	Vol. V[l]
Force (Load) [kN]	1.7	2.3	2.8	3.4	3.8	4.4	
Spring rate [N/cm]	760	990	1220	1480	1610	1820	
Natural frequency [Hz]	3.5	3.3	3.3	3.3	3.2	3.2	

Pneumatic application - static characteristic values

Force F [kN]

Pressure p [bar]	3	4	5	6	7	8	Vol.[l]	
Height H [mm]	100	1.2	1.6	2.0	2.5	3.0		3.4
	90	1.7	2.2	2.8	3.4	3.9		4.4
	80	2.1	2.8	3.5	4.2	4.9		5.3
	70	2.3	3.2	3.9	4.7	5.4		6.2
	60	2.6	3.5	4.3	5.2	6.1		6.9



Service instructions  
 M8 = 25 Nm  
 G 1/8 = 25 Nm