

FS 70-7

CONTI® Single Convolution Air Spring

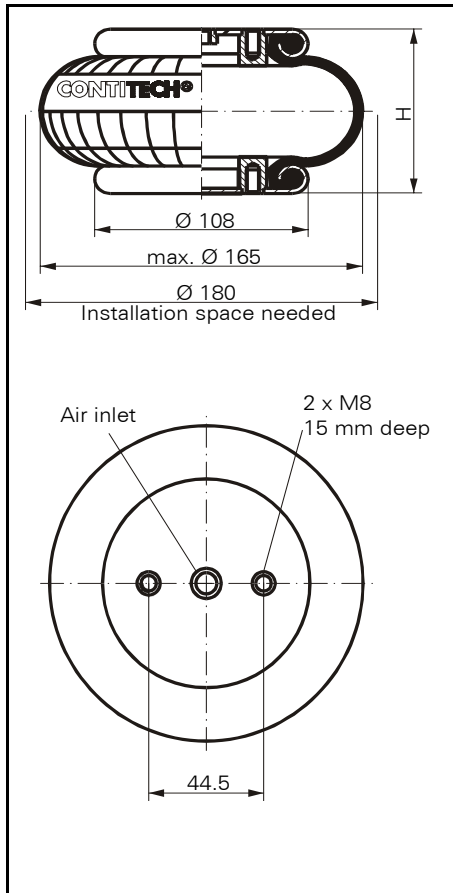

FS 70-7

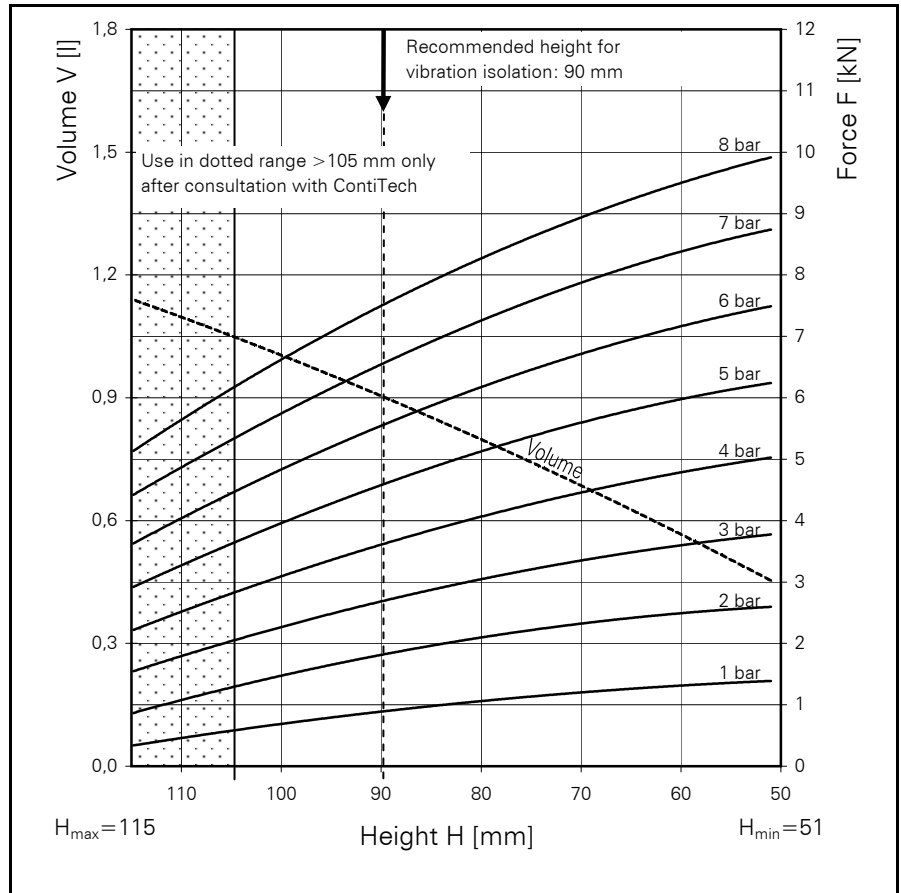

Force-height diagram

Purchase order data

Type	Order No.
Rubber bellows only	60512
With clamped plates G 1/4 air inlet 79.4 mm excentrical	2681 015 000

Additional types on request

Technical data

Min. pressure	0 bar
Return force to min. height	≤ 200 N
Overall weight with clamped plates	1.2 kg

Vibration isolation - dynamic characteristic values

Design height H: recommended 90mm, minimum 70mm

Pressure p [bar]	3	4	5	6	7	8	Vol V [l]
Force (Load) [kN]	2.7	3.7	4.7	5.7	6.6	7.7	
Spring rate [N/cm]	1040	1270	1530	1770	2060	2325	
Natural frequency [Hz]	3.1	2.9	2.9	2.8	2.8	2.7	

Pneumatic application - static characteristic values

Force F [kN]

Pressure p [bar]	3	4	5	6	7	8	Vol.[l]	
Height H [mm]	100	2.2	3.1	4.0	4.8	5.7		6.6
	90	2.7	3.6	4.6	5.6	6.5		7.5
	80	3.1	4.1	5.1	6.2	7.3		8.3
	70	3.4	4.5	5.6	6.7	7.9		9.0
	60	3.6	4.8	6.0	7.2	8.4		9.5



Service instructions
M 8 = 25 Nm
G 1/4 = 25 Nm