

	Description	Assembly Order No.
Style 100/70	Blind nuts, 1/4 NPT	W02-358-9025
Two Ply Bellows		
Assembly weight.....		1.3 kg.

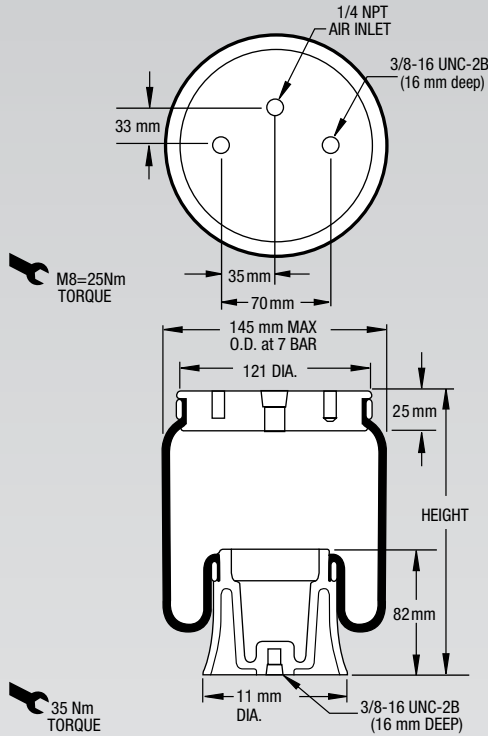

**NOTE:** Recommended operating pressure not to exceed 100 psig.

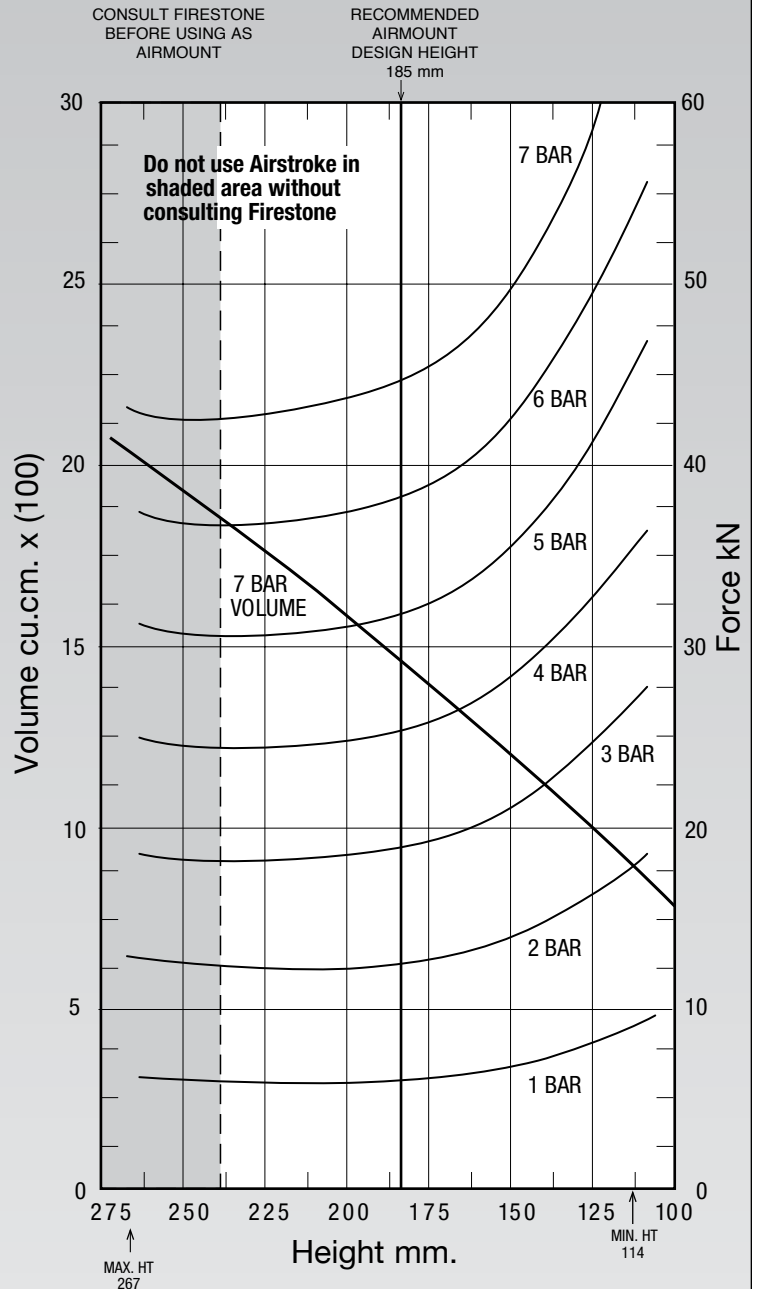

See page 12 for instructions on how to use chart.

Dynamic Characteristics at 185 mm Design Height (Required for Airmount isolator design only)			
Gauge Pressure (BAR)	Load (kN)	Spring Rate (kN/m)	Natural Frequency Hz
4	2.6	23	1.73
5	3.3	31	1.63
6	3.9	40	1.57
7	4.5	48	1.53

Force Table (Use for Airstroke™ actuator design)							
Assembly Height (mm)	Volume @ 7 BAR (cu cm)	EFF Area @ 7 BAR (cm sq)	kN Force				
			@ 3 BAR	@ 4 BAR	@ 5 BAR	@ 6 BAR	@ 7 BAR
250	1940.9	61.5	1846	2462	3077	3693	4308
225	1757.8	60.9	1827	2436	3045	3654	4263
200	1565.0	62.3	1868	2490	3113	3735	4358
175	1373.9	64.2	1926	2568	3210	3852	4494
150	1180.8	70.5	2114	2818	3523	4227	4932
125	976.0	82.6	2479	3306	4132	4959	5785