

Description		Assembly Order No.
Style 110/70	Blind nut, 1/4 NPT	W26-358-9025
Two Ply Bellows		
Assembly weight.....		1.5 lbs.

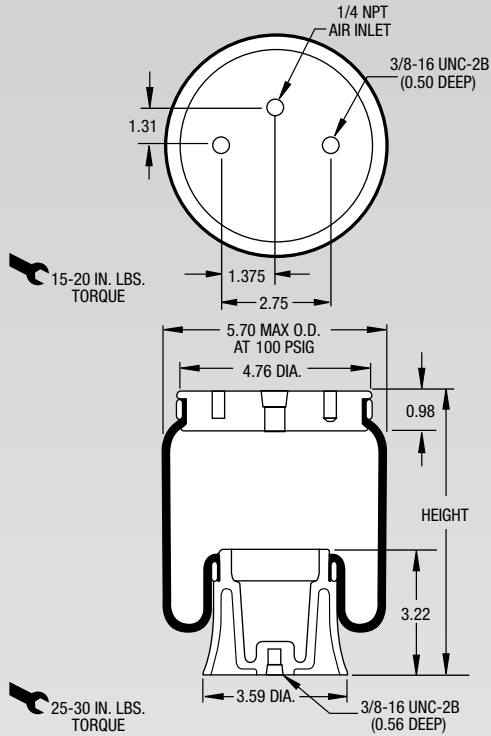

CONSULT FIRESTONE  
BEFORE USING AS  
AIRMOUNT

RECOMMENDED  
AIRMOUNT  
DESIGN HEIGHT  
7.25 INCHES

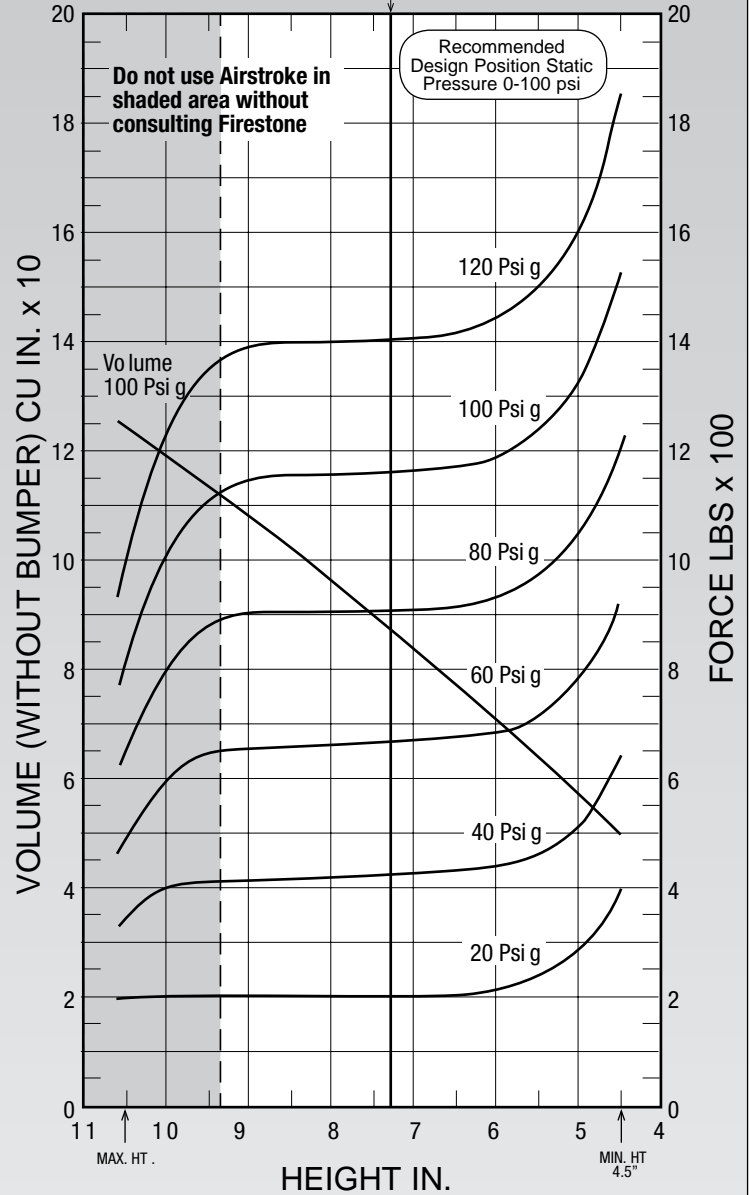

**NOTE:** Recommended operating pressure not to exceed 100 psig.

**Dynamic Characteristics at 7.25 in. Design Height**  
(Required for Airmount isolator design only)

Volume @ 100 PSIG = 87 in <sup>3</sup>			Natural Frequency	
Gage Pressure (PSIG)	Load (lbs.)	Spring Rate (lbs./in.)	CPM	HZ
40	430	132	104	1.73
60	670	181	98	1.63
80	910	230	94	1.57
100	1160	279	92	1.53

See page 12 for instructions on how to use chart.

**Force Table (Use for Airstroke™ actuator design)**

Assembly Height (in.)	Volume @ 100 PSIG (in <sup>3</sup> )	Pounds Force				
		@20 PSIG	@40 PSIG	@60 PSIG	@80 PSIG	@100 PSIG
9	108	200	415	655	900	1145
8	96	200	415	655	910	1155
7	84	205	430	670	915	1160
6	71	220	445	690	935	1200
5	58	300	515	790	1050	1325