

	Description	Assembly Order No.
Style 16-ST	Blind nuts, 1/4 BSP	W02-M58-5001
	Stainless steel plates	W02-M58-5003
Two Ply Bellows		
Assembly weight.....		0.58 kg.
Force to collapse to minimum height (@ 0 BAR)		35.5 N.

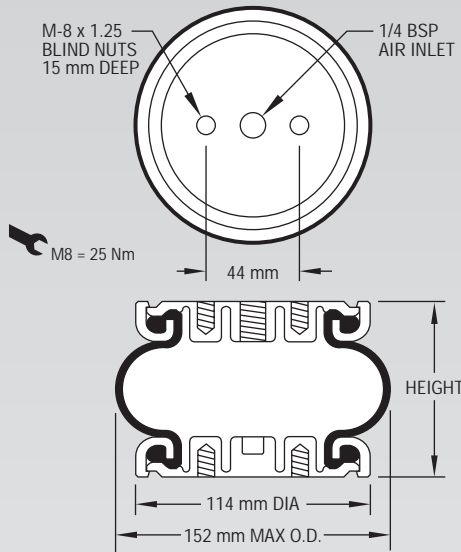

NOTE: The bellows extends beyond the bead plates at minimum height.

RECOMMENDED
AIRMOUNT
DESIGN HEIGHT
75 mm.

Static Data
B4165

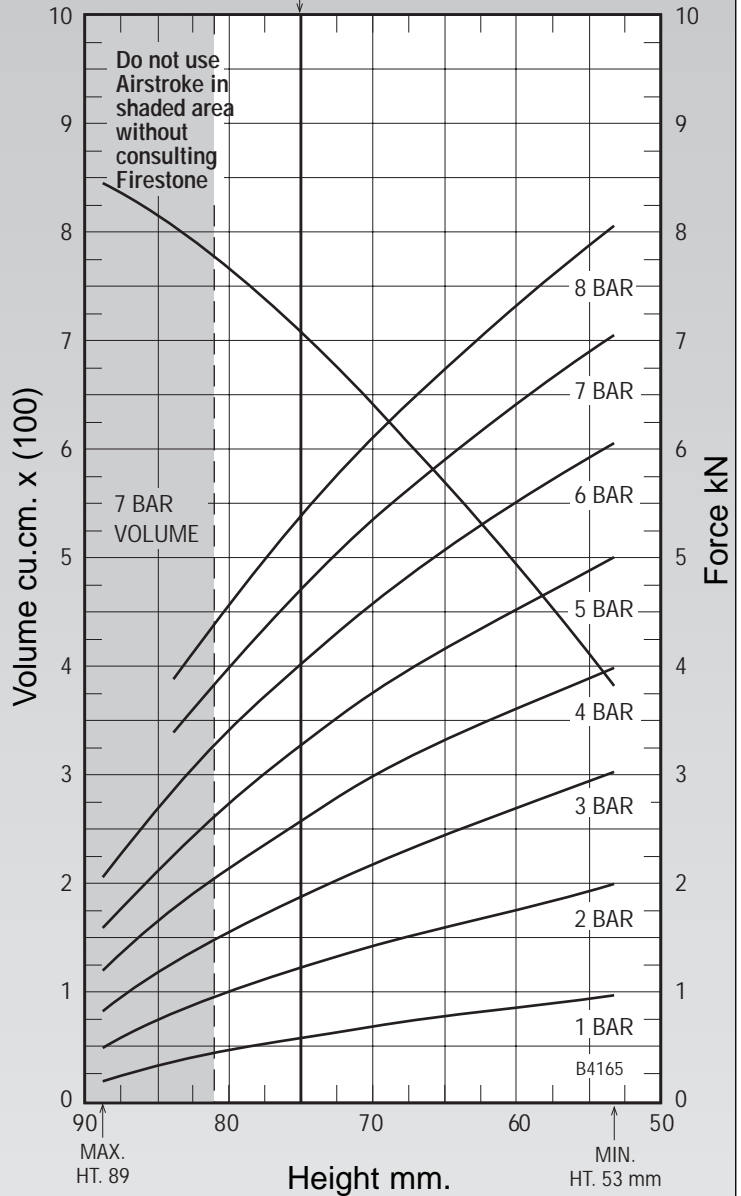

See page 12 for instructions on how to use chart.

Dynamic Characteristics at 75 mm Design Height (Required for Airmount isolator design only)			
Gauge Pressure (BAR)	Load (kN)	Spring Rate (kN/m)	Natural Frequency Hz
3	1.85	132.58	4.22
4	2.53	171.56	4.11
5	3.2	209.02	4.07
6	3.94	246.21	3.94
7	4.59	281.12	3.9

Force Table (Use for Airstroke™ actuator design)							
Assembly Height (mm)	Volume @ 7 BAR (cu cm)	EFF Area @ 7 BAR (cm**2)	kN Force				
			@ 3 BAR	@ 4 BAR	@ 5 BAR	@ 6 BAR	@ 7 BAR
80	460	55.24	1.52	2.07	2.64	3.29	3.87
75	426	65.63	1.85	2.53	3.20	3.94	4.59
70	386	75.10	2.14	2.93	3.69	4.51	5.26
65	343	83.28	2.42	3.27	4.11	5.00	5.83
60	303	90.11	2.67	3.56	4.46	5.42	6.31
55	256	97.34	2.92	3.86	4.83	5.86	6.81