

FS 120-12

CONTI® Single Convolution Air Spring

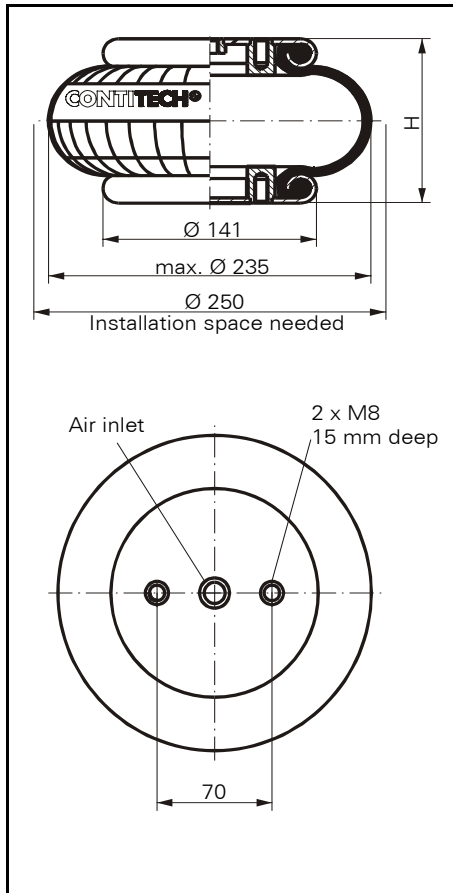

FS 120-12

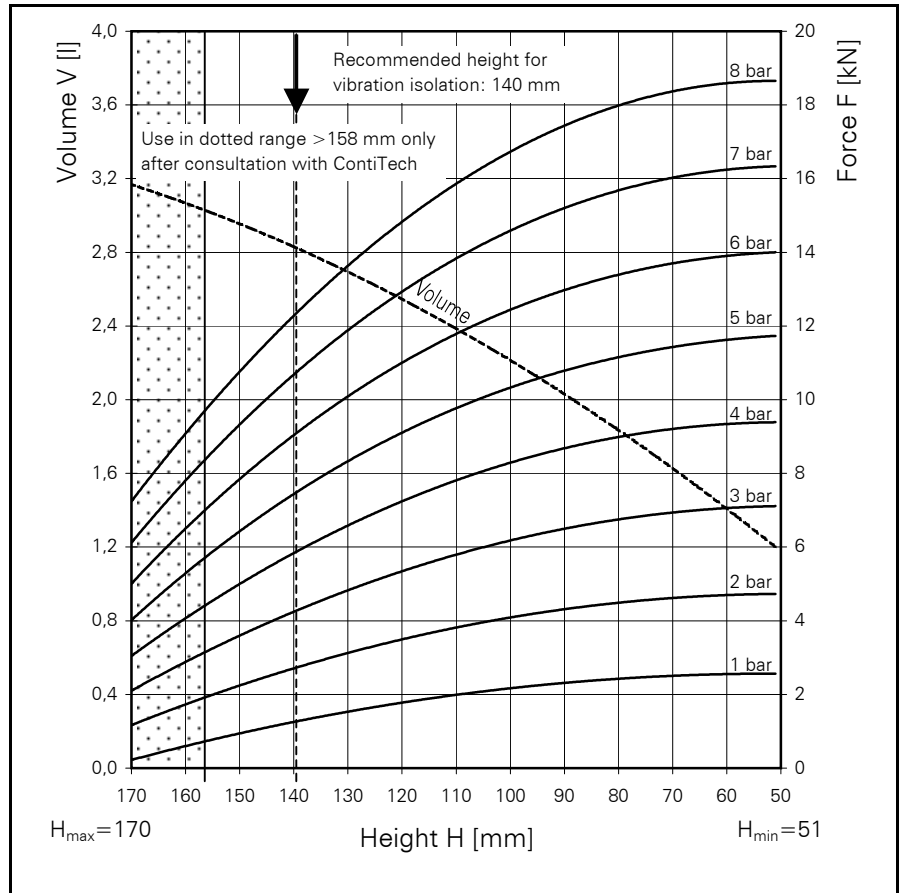

Force-height diagram

Purchase order data

Type	Order No.
Rubber bellows only	on request
With clamped plates G 1/4 air inlet	on request
With clamped plates G 3/4 air inlet	on request

Additional types on request

Technical data

Min. pressure	0 bar
Return force to min. height	≤ 200 N
Overall weight with clamped plates	1.9 kg

Vibration isolation - dynamic characteristic values

Design height H: recommended 140mm, minimum 125mm

Pressure p [bar]	3	4	5	6	7	8	Vol V [l]
Force (Load) [kN]	4.2	5.8	7.3	8.9	10.4	12.0	2.8
Spring rate [N/cm]	1160	1450	1730	2020	2300	2580	
Natural frequency [Hz]	2.6	2.5	2.4	2.4	2.4	2.3	

Pneumatic application - static characteristic values

Force F [kN]

Pressure p [bar]	3	4	5	6	7	8	Vol.[l]	
Height H [mm]	150	3.7	5.1	6.5	7.9	9.4	10.8	2.9
	130	4.9	6.6	8.3	10.1	11.9	13.7	2.7
	110	5.8	7.8	9.8	11.8	13.8	15.9	2.4
	90	6.5	8.8	10.8	13.0	15.2	17.4	2.0
	70	6.9	9.2	11.4	13.7	16.0	18.3	1.6



Service instructions
M 8 = 25 Nm
G 1/4 = 25 Nm